

# **User Manual**

## **6K/10K Online Modular UPS**

### **Uninterruptible Power Supply System**

Version: 1.6



**Please comply with all warnings and operating instructions in this manual strictly. Save this manual properly and read carefully the following instructions before installing the unit. Do not operate this unit before reading through all safety information and operating instructions carefully.**

# Table of Contents

<b>1. Safety and EMC instructions .....</b>	<b>1</b>
1-1. Transportation and Storage.....	1
1-2. Preparation .....	1
1-3. Installation .....	1
1-4.  Connection Warnings.....	2
1-5. Operation.....	2
1-6. Standards .....	3
<b>2. Installation.....</b>	<b>4</b>
2-1. Unpacking and Inspection .....	4
2-2. Rear Panel View .....	5
2-3. Rack/Tower Installation .....	6
2-4. Single UPS Installation .....	10
2-5. Parallel UPS Installation .....	11
2-6. Battery Pack Installation .....	11
<b>3. Operations.....</b>	<b>14</b>
3-1. Operation Mode.....	14
3-2. UPS Module Introduction.....	18
3-3. Single UPS Operation .....	20
3-4. LCD Operation on UPS Module .....	23
3-5. Parallel UPS Operation .....	37
<b>4. Trouble Shooting.....</b>	<b>38</b>
4-1. Warning status.....	38
4-2. Fault mode.....	38
4-3. Trouble shooting table .....	38
<b>5. Storage and Maintenance .....</b>	<b>42</b>
5-1. Storage.....	42
5-2. Maintenance.....	42
<b>6. Specifications .....</b>	<b>43</b>

# 1. Safety and EMC instructions

Please read carefully the following user manual and the safety instructions before installing the unit or using the unit!

## 1-1. Transportation and Storage



Please transport the UPS system only in the original package to protect against shock and impact.



The UPS must be stored in the room where it is ventilated and dry.

## 1-2. Preparation



Condensation may occur if the UPS system is moved directly from cold to warm environment. The UPS system must be absolutely dry before being installed. Please allow at least two hours for the UPS system to acclimate the environment.



Do not install the UPS system near water or in moist environments.



Do not install the UPS system where it would be exposed to direct sunlight or nearby heater.



Do not block ventilation holes in the UPS housing.

## 1-3. Installation



Do not connect appliances or devices which would overload the UPS (e.g. big motor-type equipment)).



Place cables in such a way that no one can step on or trip over them.



Do not block air vents in the housing of UPS. The UPS must be installed in a location with good ventilation. Ensure enough space on each side for ventilation.



UPS has provided earthed terminal, in the final installed system configuration, equipotential earth bonding to the external UPS battery cabinets.



The UPS can be installed only by qualified maintenance personnel.



An appropriate disconnect device as short-circuit backup protection should be provided in the building wiring installation.



An integral single emergency switching device which prevents further supply to the load by the UPS in any mode of operation should be provided in the building wiring installation.



Connect the earth before connecting to the building wiring terminal.



Installation and Wiring must be performed in accordance with the local electrical laws and regulations.

## 1-4. Connection Warnings

- There is no standard backfeed protection inside, please isolate the UPS before working according to this circuit. The isolation device must be able to carry the UPS input current.

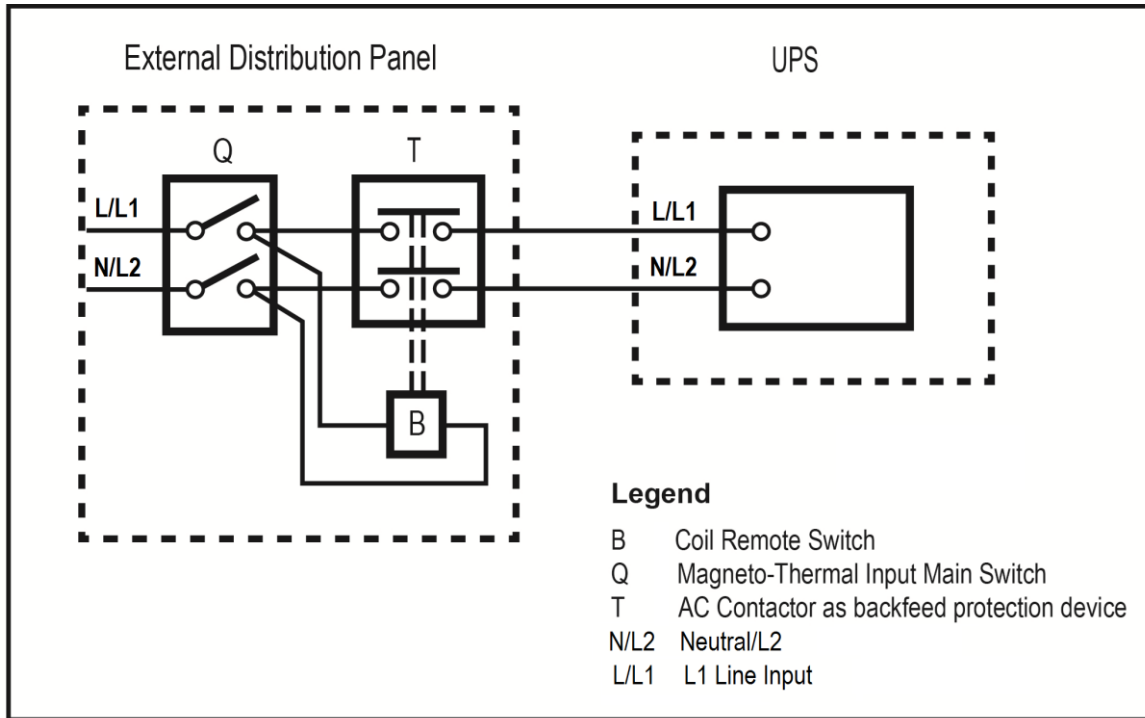

- This UPS should be connected with **TN** earthing system.
- The input power supply rating must be in accordance with your equipment (i.e., 3-phase, 2-phase or single-phase.) It also must be suitably grounded.
- Use of this equipment in life support applications where failure of this equipment can reasonably be expected to cause the failure of the life support equipment or to significantly affect its safety or effectiveness is not recommended. Do not use this equipment in the presence of a flammable anesthetic mixture with air, oxygen or nitrous oxide.
- Connect your UPS power module's grounding terminal to a grounding electrode conductor.
- The UPS is connected to a DC energy source (battery). The output terminals may be live when the UPS is not connected to an AC supply.

### **Before working on this circuit**

- Isolate Uninterruptible Power System (UPS)
- Then check for Hazardous Voltage between all terminals including the protective earth.



**Risk of Voltage Backfeed**

## 1-5. Operation



Do not disconnect the earth conductor cable on the UPS or the building wiring terminals in any time since this would cancel the protective earth of the UPS system and of all connected loads.



If the external battery cabinet is connected, the UPS output Anderson connector may be electrically live even if the UPS system is not connected to the building wiring outlet.



In order to fully disconnect the UPS system, first press the "OFF" button and then disconnect the mains.



Ensure that no liquid or other foreign objects can enter into the UPS system.



The UPS can be operated by any individuals with no previous experience.

## 1-6. Standards

For 3-3 10K, 3-1 10K, 1-1 10K

<b>* Safety</b>	
IEC/EN 62040-1	
<b>* EMI</b>	
Conducted Emission.....:IEC/EN 62040-2	Category C3
Radiated Emission.....:IEC/EN 62040-2	Category C3
<b>*EMS</b>	
ESD.....:IEC/EN 61000-4-2	Level 4
RS..... :IEC/EN 61000-4-3	Level 3
EFT..... :IEC/EN 61000-4-4	Level 4
SURGE..... :IEC/EN 61000-4-5	Level 4
CS..... :IEC/EN 61000-4-6	Level 3
Power-frequency Magnetic field..... :IEC/EN 61000-4-8	Level 4
Low Frequency Signals.....:IEC/EN 61000-2-2	
<b>Warning:</b> This is a product for commercial and industrial application in the second environment-installation restrictions or additional measures may be needed to prevent disturbances.	

For 2-2 6K LV, 3-3 10K LV

<b>* Safety</b>	
IEC/EN 62040-1	
<b>* EMI</b>	
Conducted Emission.....: FCC 47 CFR15, Subpart B	Class A
Radiated Emission.....: FCC 47 CFR15, Subpart B	Class A
<b>*EMS</b>	
ESD.....:IEC/EN 61000-4-2	Level 4
RS..... :IEC/EN 61000-4-3	Level 3
EFT..... :IEC/EN 61000-4-4	Level 4
SURGE..... :IEC/EN 61000-4-5	Level 4
CS..... :IEC/EN 61000-4-6	Level 3
Power-frequency Magnetic field..... :IEC/EN 61000-4-8	Level 4
Low Frequency Signals.....:IEC/EN 61000-2-2	
<b>Warning:</b> This is a product for commercial and industrial application in the second environment-installation restrictions or additional measures may be needed to prevent disturbances.	

## 2. Installation

There are five types of models in this series:

Model	Type
2-2 6K LV	2-phase online UPS
3-3 10K LV	3-phase in/3-phase out 208V online UPS
3-3 10K	3-phase in/3-phase out 400V online UPS
3-1 10K	3-phase in/single phase out online UPS
1-1 10K	Single phase online UPS

### 2-1. Unpacking and Inspection

We offer two different accessory packages for UPS module and battery pack: standard system pack and standalone pack.

- Standard system pack: This package will be delivered when purchasing mini system cabinet from the supplier. In this condition, UPS module only can be installed into the cabinet.
- Standalone pack will be delivered when only purchasing the UPS module. When purchasing standalone pack, the UPS and battery pack can be installed either flatly in the 19" cabinet or vertically in floor-standing tower.

Included with all UPS modules:

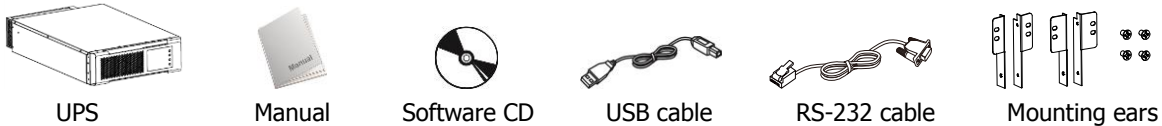

Included with all battery pack:



Included with UPS modules in standalone pack:

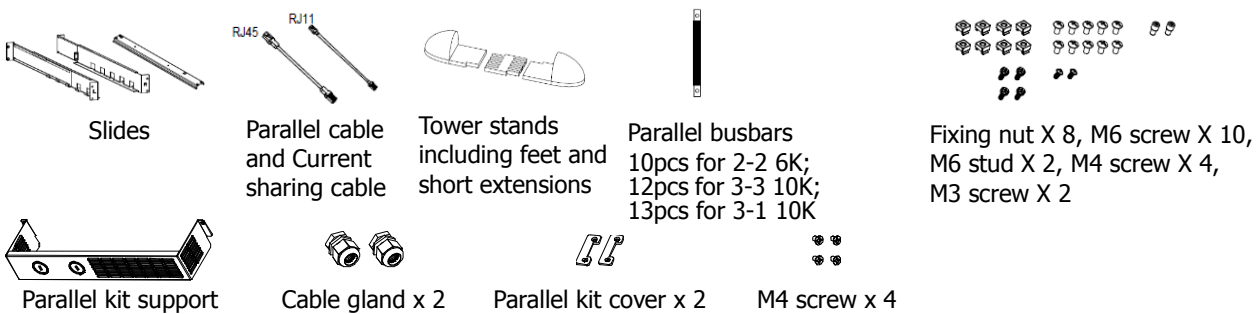

Included with battery pack in standalone pack:

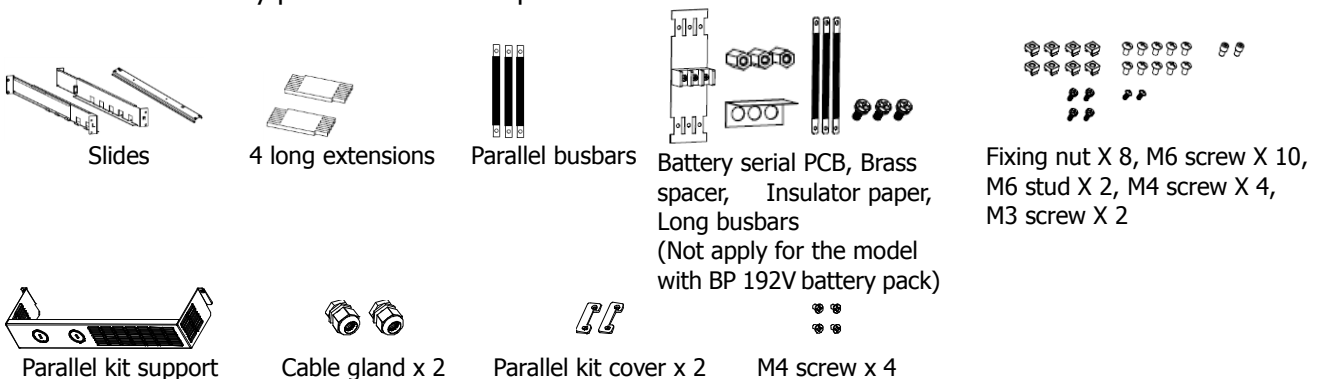

**NOTE:** Before installation, please inspect the unit. Be sure that nothing inside the package is damaged during transportation. Do not turn on the unit and notify the carrier and dealer immediately if there is any damage or lacking of some parts. Please keep the original package in a safe place for future use.

**2-2. Rear Panel View**

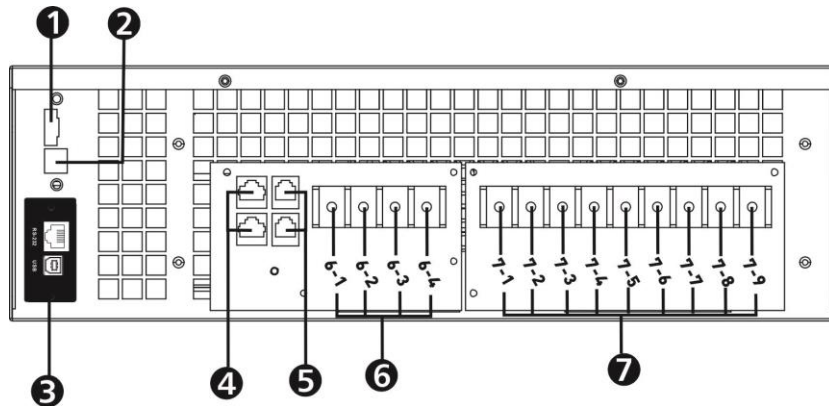

**Diagram 1: 6KRT/10KRT rear panel**

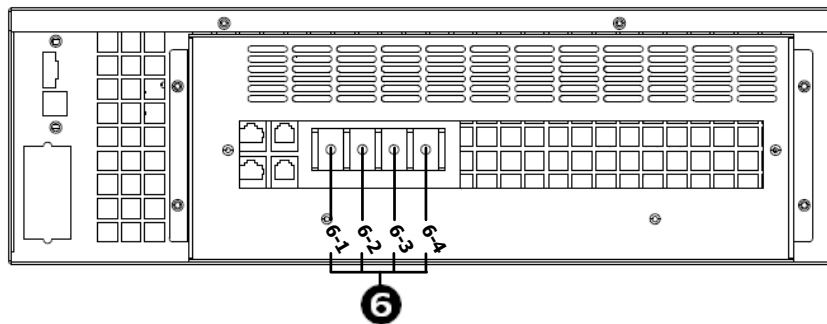

**Diagram 2: Battery pack rear panel**

1. EPO (Emergency Power Off) connector
2. USB communication port
3. Intelligent card including RS-232 and USB communication ports
4. Parallel port (for parallel function)
5. Current sharing port (for parallel function)
6. Battery terminal
7. Input/ Output terminal

**Battery Terminal Configuration**

Model	Battery Terminal			
	6-1	6-2	6-3	6-4
2-2 6K LV	BAT +	BAT-N	BAT -	
3-3 10K, 3-3 10K LV	BAT +	BAT-N	BAT -	
3-1 10K	BAT +	BAT-N	BAT -	R- bypass
1-1 10K	BAT +	BAT-N	BAT -	R- bypass

**Input/Output Terminal Configuration**

Model	Input/ Output Terminal								
	7-1	7-2	7-3	7-4	7-5	7-6	7-7	7-8	7-9
2-2 6K LV	I/P-R	I/P-N		I/P-T	PE	OP-L1		OP-L3	OP-N
3-3 10K, 3-3 10K LV	I/P-R	I/P-N	I/P-S	I/P-T	PE	OP-L1	OP-L2	OP-L3	OP-N
3-1 10K	I/P-R	I/P-N	I/P-S	I/P-T	PE	OP-L	OP-L	OP-N	OP-N
1-1 10K	I/P-R	I/P-N	I/P-R	I/P-R	PE	OP-L	OP-L	OP-N	OP-N



## 2-3. Rack/Tower Installation

### 2-3-1. Tower Installation

The UPS module is shipped with two sets of feet and 2 short extensions that can be used to tower install the UPS module in 3U. Battery pack is shipped with 4 long extensions that can be used to install UPS module and one battery pack in 6U.

#### Install UPS module in 3U

Assemble two feet and one short extension as one tower stand shown in step 1. Align the two stands approximately 35cm apart in step 2. Then, put UPS module in the stands as shown in step 3.

**NOTE:** Make sure the connector box is firmly attached to UPS back panel with screws.

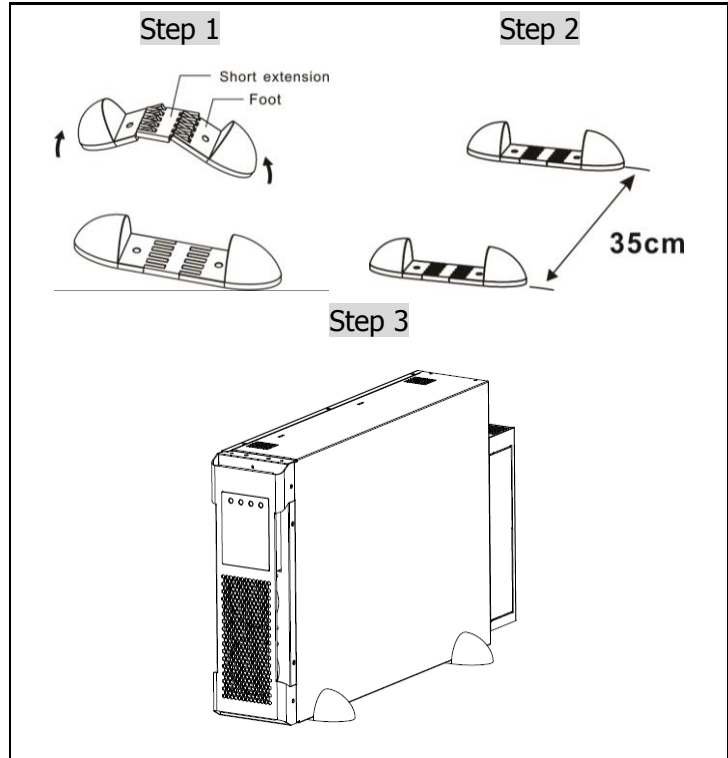

#### Install UPS module and one battery pack in 6U or two battery packs in 9U

Assemble two feet and two long extensions as one tower stand shown in step 1. Align the two stands approximately 35cm apart in step 2. Then, put UPS module and battery pack in the stands as shown in step 3.

If two battery packs are installed with UPS together, please use three long extensions for each tower stand. Then, put UPS module and two battery packs in the stands as shown in step 4.

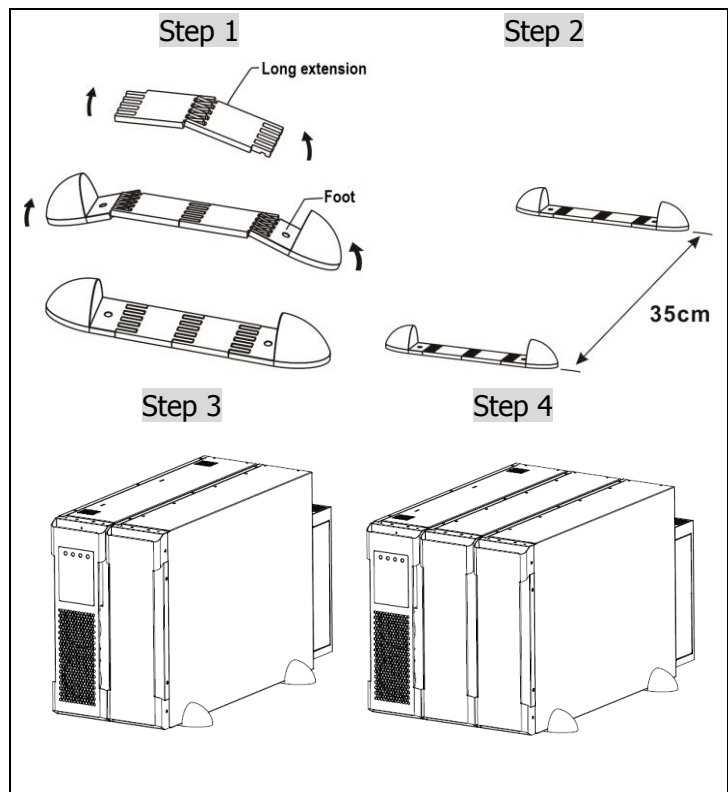

If ordering standalone pack, it's bundled with fixing kits. Refer to right chart for installation method. For the bottom side, it's not necessary to install since these units are heavy.

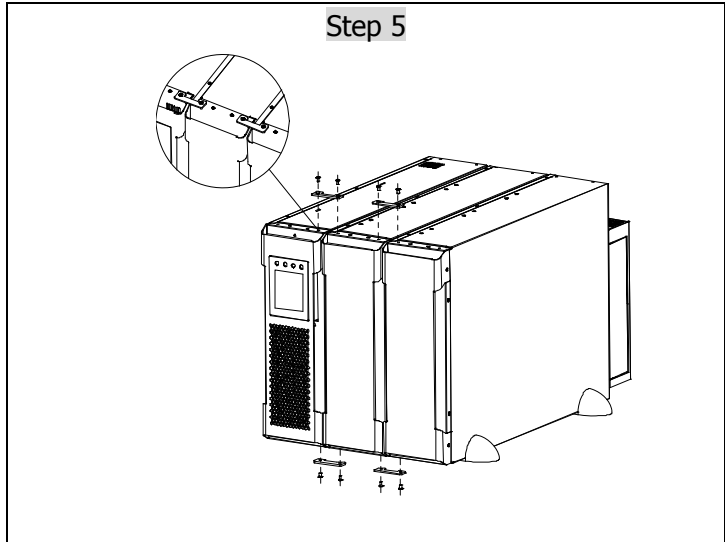

On the back side, please follow wiring direction to install cable glands into parallel kit support or bottom/top terminal case. First, dis-assemble the cable gland. Remove the metal plates from the parallel kit support and terminal case. Then, install cable glands into the holes as shown in the right chart.

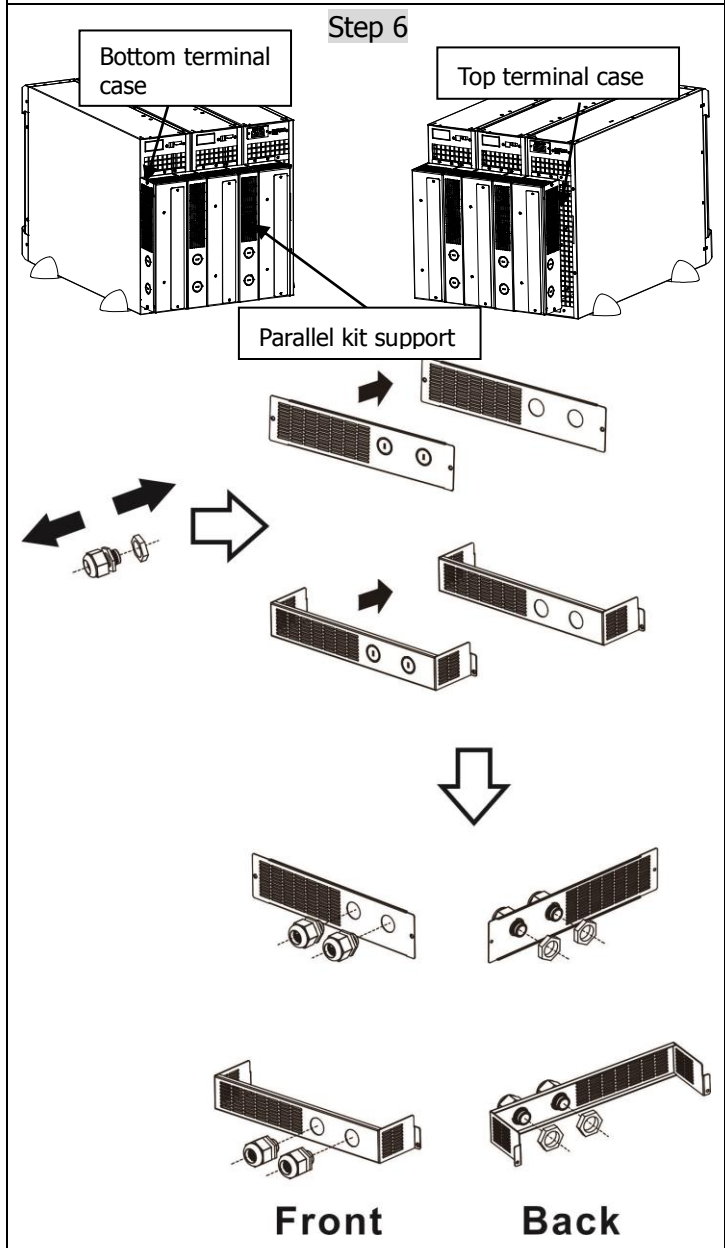

### 2-3-2. Rack Installation

Please follow below steps to mount UPS/battery pack into 19" rack or rack enclosure.

**Step 1:** Insert 8 pieces of fixing nuts into the following locations to fix rail sliders and UPS.

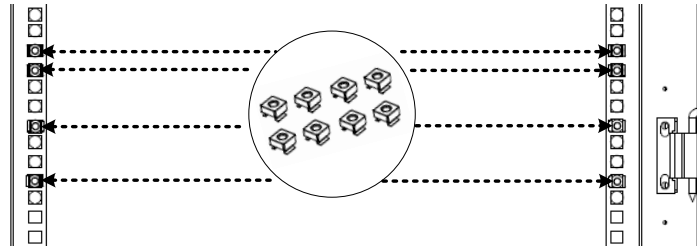

**Step 2:** Use 4 pieces of M6 screws to mount rail sliders into front of the chassis.

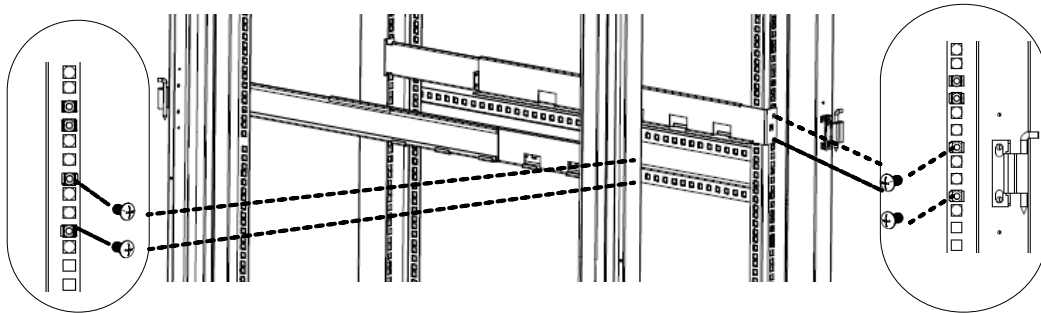

**Step 3:** Adjust the distance of rail sliders by pulling the other end. It should be the same depth of rack chassis. For example, if depth of rack chassis is 900mm, please pull the length of rail sliders in 900mm. Then, use 2 pieces of M6 screws and 2 pieces of M6 studs to the mount rail sliders into the back of the chassis.

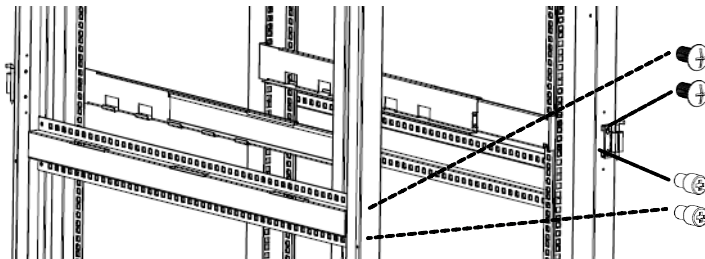

**Step 4:** Fixing the slide-bone into the middle of two sliders with 4 pieces of M4 screws. See chart below.

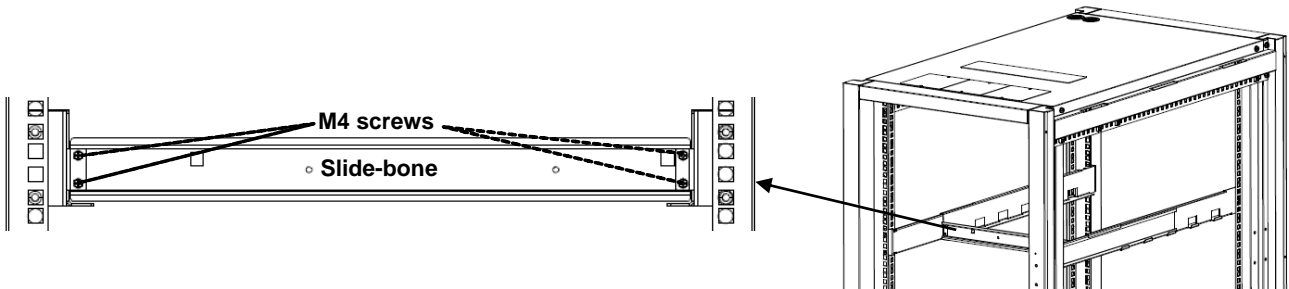

**Step 5:** Remove top or bottom terminal case by 2 screws separately if necessary.

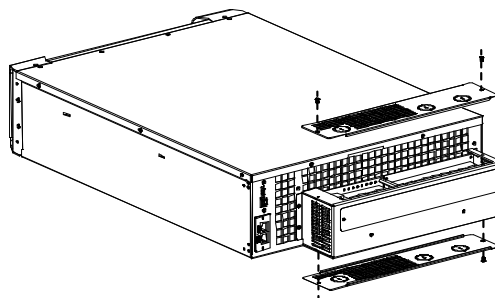

**Step 6:** Attach mounting ears to the side mounting holes of UPS module by using the screws provided and the ears should face forward as following picture show.

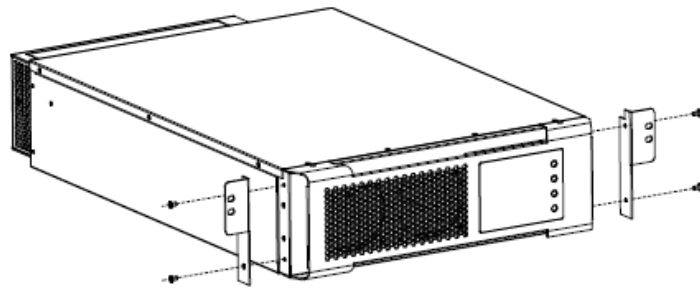

**Step 7:** Put the UPS module on the sliders and push it toward slide bone. Fixing the connector box with slide-bone by 2 pieces of M3 screws. See chart below.

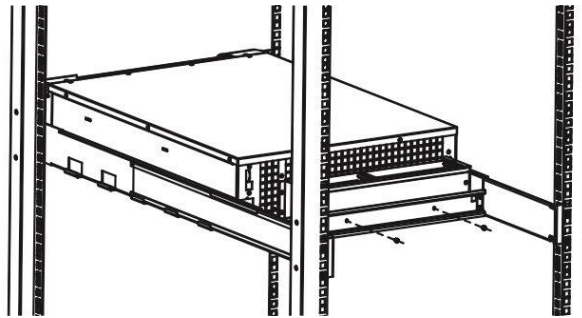

**Step 8:** Disassemble the connector box from UPS by removing 4 screws.

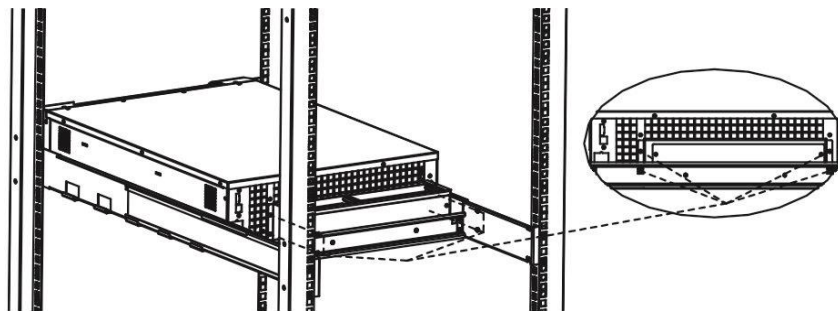

**Step 9:** Please make sure hot-swappable connectors on connector box are firmly plugged into the UPS module. Fasten the UPS module to the chassis with screws on the mounting ears.

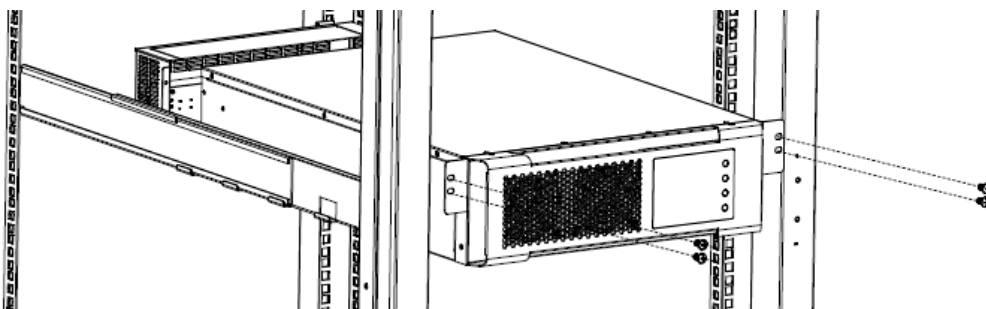

**Step 10:** Install the battery pack with the same procedure as UPS module.

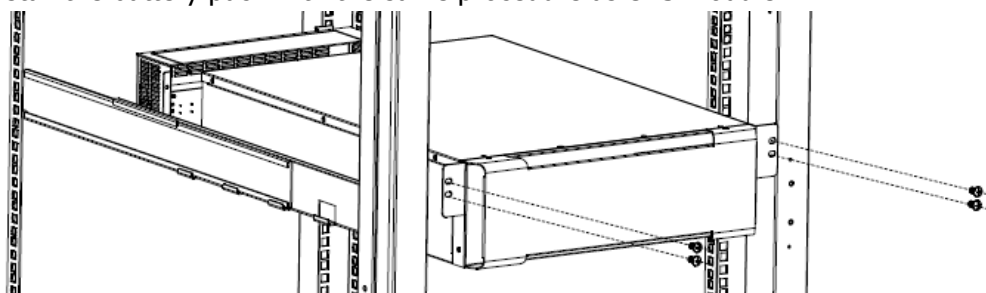

## 2-4. Single UPS Installation

Installation and wiring must be performed in accordance with the local electric laws/regulations and execute the following instructions by professional personnel.

1) Make sure the mains wire and breakers in the building are enough for the rated capacity of UPS to avoid the hazards of electric shock or fire.

**NOTE:** Do not use the wall receptacle as the input power source for the UPS, as its rated current is less than the UPS's maximum input current. Otherwise the receptacle may be burned and destroyed.

2) Switch off the mains switch in the building before installation.

3) Turn off all the connected devices before connecting to the UPS.

4) Prepare wires based on the following table:

Model	Wiring spec (AWG)			
	Input	Output	Battery	Ground
2-2 6K LV, 3-3 10K LV	10	10	10	10
3-3 10K, 3-1 10K, 1-1 10K	12	12	12	12

**NOTE 1:** The cable for 6K should be able to withstand over 35A current. It is recommended to use 10AWG or thicker wire for safety and efficiency.

**NOTE 2:** The cable for 10K should be able to withstand over 30A current. It is recommended to use 12AWG or thicker wire for safety and efficiency.

**NOTE 3:** The selections for color of wires should be followed by the local electrical laws and regulations.



### Warning:

- For external battery pack, make sure a DC breaker or other protection device between UPS and external battery pack is installed. If not, please install it carefully. Switch off the battery breaker before installation.

**NOTE:** Set the battery pack breaker in "OFF" position and then install the battery pack.

- Pay highly attention to the rated battery voltage marked on the rear panel. If you want to change the numbers of the battery pack, please make sure you modify the setting simultaneously. The connection with wrong battery voltage may cause permanent damage of the UPS. Make sure the voltage of the battery pack is correct.
- Pay highly attention to the polarity marking on external battery connector and make sure the correct battery polarity is connected. Wrong connection may cause permanent damage of the UPS.
- Make sure the protective earth ground wiring is correct. The wire current spec, color, position, connection and conductance reliability should be checked carefully.
- Make sure the utility input & output wiring is correct. The wire current spec, color, position, connection and conductance reliability should be checked carefully. Make sure the L/N site is correct, not reverse and short-circuited.

## 2-5. Parallel UPS Installation

For parallel UPS system installation, please follow Section 2-3-2 Rack Installation to install required UPS modules into 19" rack or rack enclosure first. Then, connect the parallel busbars (with black sleeve), parallel cable and current sharing cable on the connector box of the top two UPSs as below chart. Apply the same connection way if more parallel modules are required.

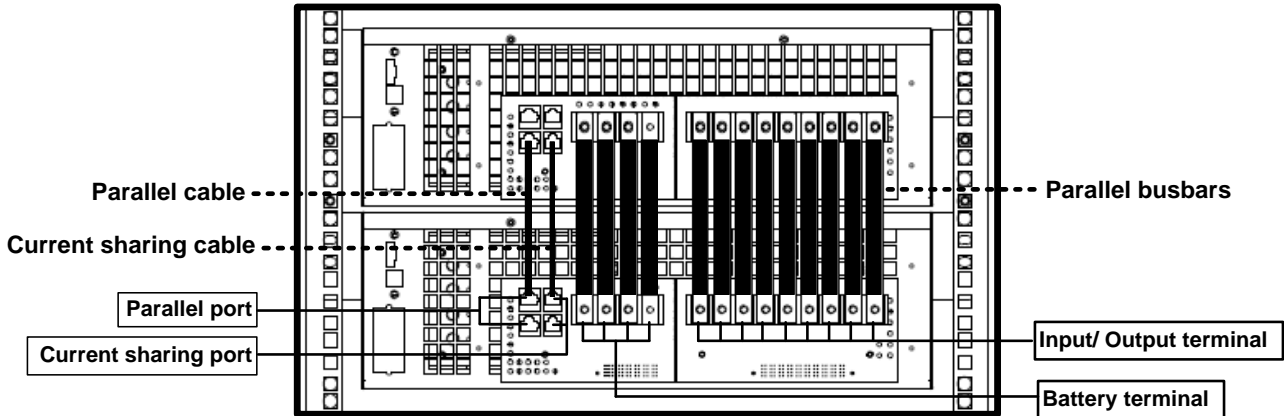

**NOTE:** For the detailed connection for parallel busbars in each terminal, please refer to the terminal configurations on 2-2.

## 2-6. Battery Pack Installation

There are three types of battery pack. Please refer to the following configuration for each UPS model.

Model	Battery voltage	Total battery numbers (pcs)	Applicable battery capacity	Applicable UPS model	Minimum required QTY per UPS module (pcs)
BP 96-120V	+/-96V ~ +/-120V	16~20	7Ah/9Ah/10Ah	2-2 6K LV	1
				3-3 10K LV	1
				3-3 10K	2 (serial connection as one group)
				3-1 10K	
BP 96V x 2	±96V x 2	32 (16 pcs x 2 strings)	5Ah	2-2 6K LV	1
				3-3 10K LV	1
BP 192V	±192V	32	5Ah	3-3 10K	1
				3-1 10K	1
				1-1 10K	1

### 2-6-1 Single Battery Pack Connection

Connect the battery terminals of battery pack and UPS module with parallel busbars as below chart.

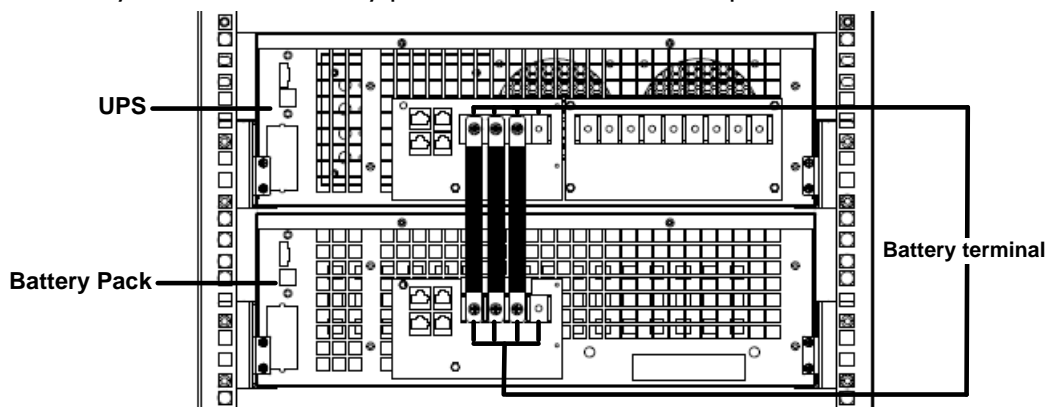

## 2-6-2 Serial Connection for Battery Packs

Before wiring connection, please follow Section 2-3-2 Rack Installation to install required battery packs into 19" rack or rack enclosure first. For the serial connection for multiple battery packs, please follow below steps.

**Step 1:** Fix the battery serial PCB to the back PCB of battery packs with 6 screws.

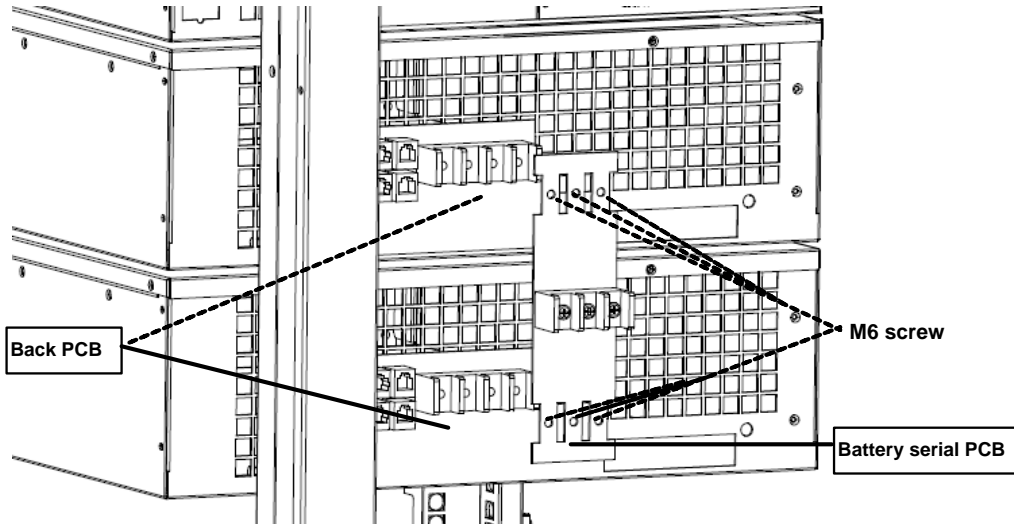

**Step 2:** Remove 3 pieces of original screws on battery terminals of UPS and fix brass spacer instead. Insert insulator papers to each battery terminal. Then, screw one end of the long busbars to the brass spacer on the UPS module and the other end to terminal of serial PCB on battery pack as below chart.

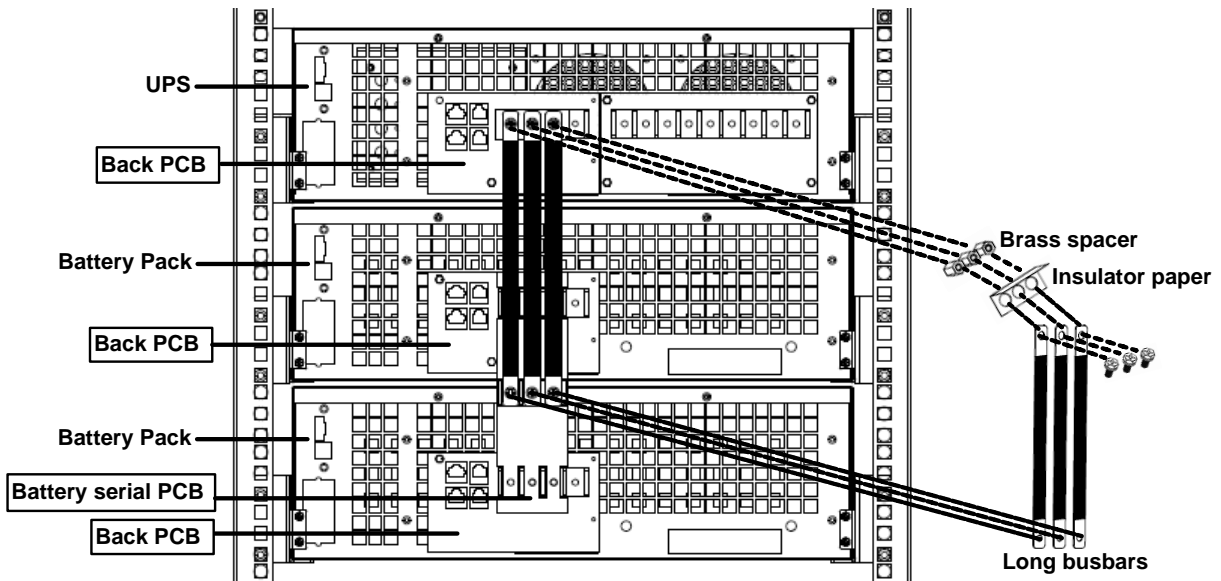

The wiring connection for parallel UPS system with serial connection of two battery packs is shown as below.

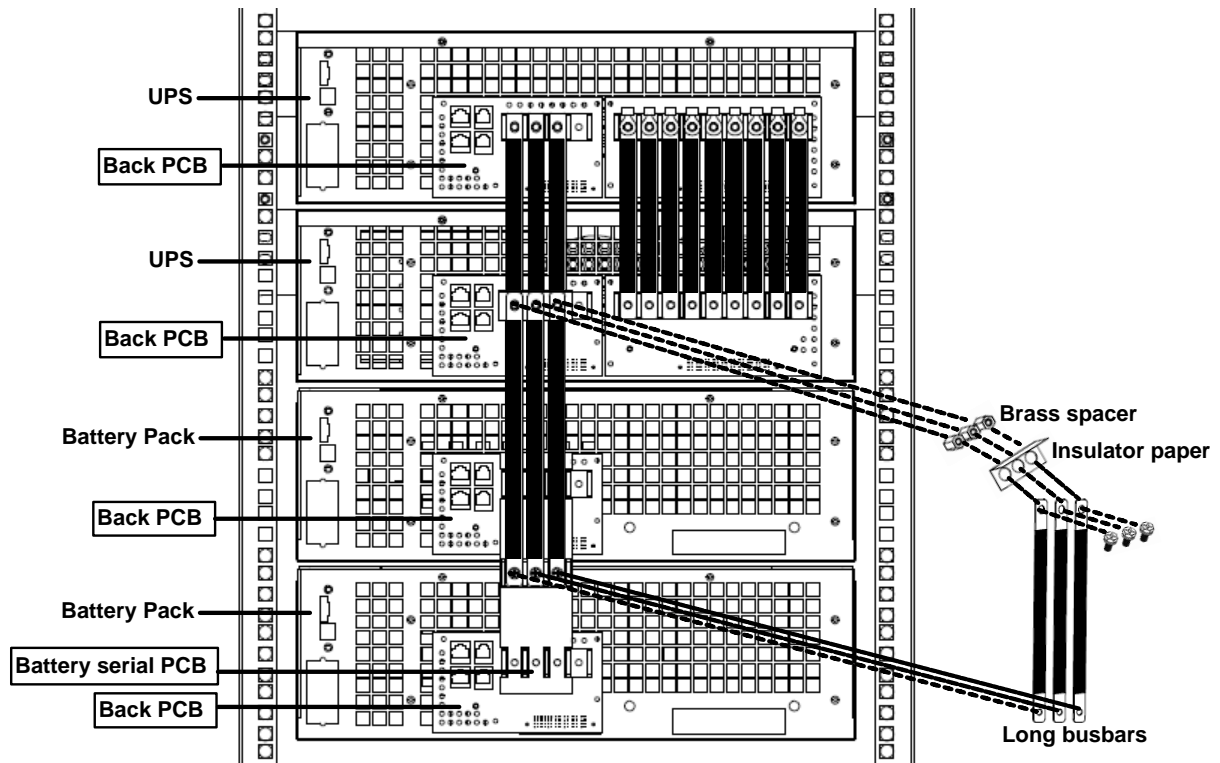

**NOTE:** For the detailed connection for parallel busbars in each terminal, please refer to the terminal configurations on 2-2.

The wiring connection for parallel UPS system with serial connection of four battery packs is shown as below.

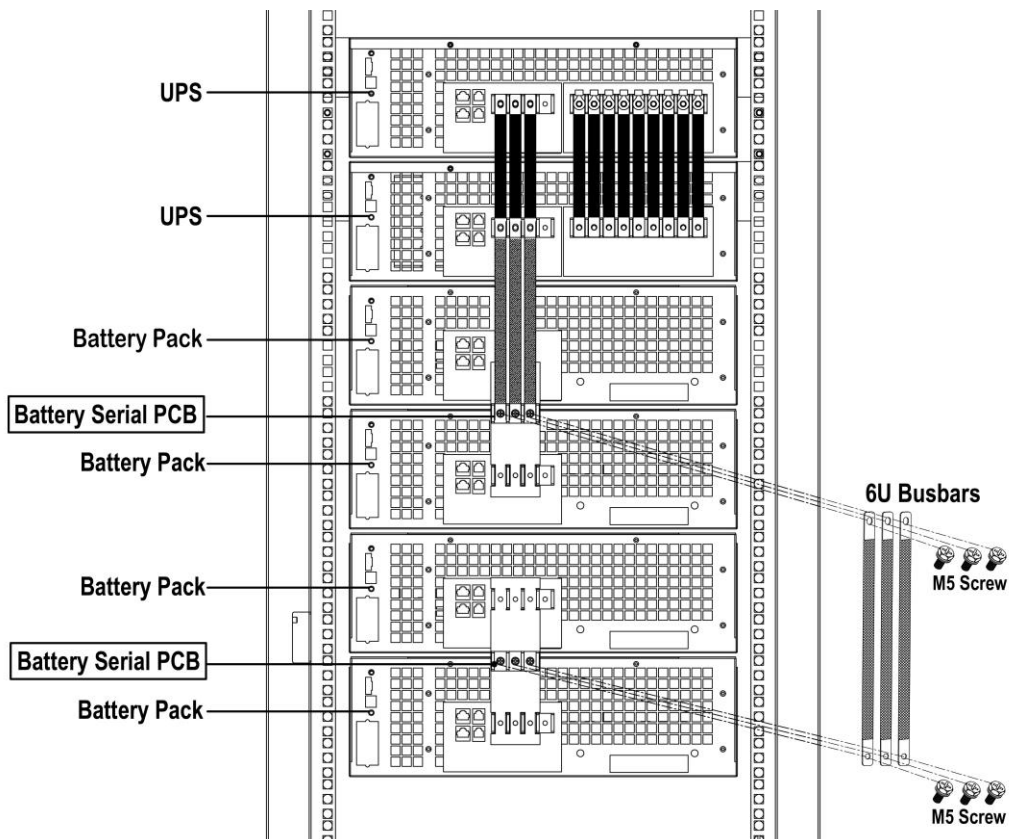



## 3. Operations

### 3-1. Operation Mode

This modular UPS is on-line, double-conversion and reverse-transfer UPS that permits operation in the following modes:

- Power On Mode
- Standby Mode
- Bypass Mode
- Line Mode
- Battery Mode
- Battery Test Mode
- Fault Mode
- CVCF Mode
- ECO Mode
- Shutdown Mode

#### 3-1-1. Power On Mode

Upon connecting to utility input power or UPS cold start, the UPS is in Power On mode. The load is not powered under this mode.

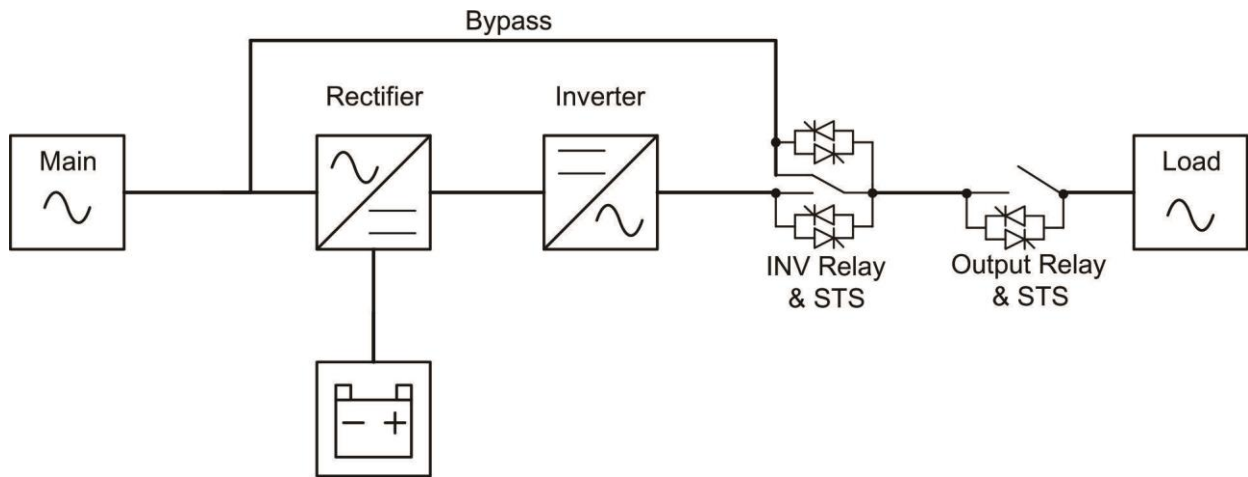

Power On Mode Diagram

#### 3-1-2. Standby Mode

Upon connecting to utility input power, the UPS is in Standby mode before UPS is turned on (if BYPASS enable setting is Disabled), and charger function will be active when the battery is present. The load is not powered under this mode.

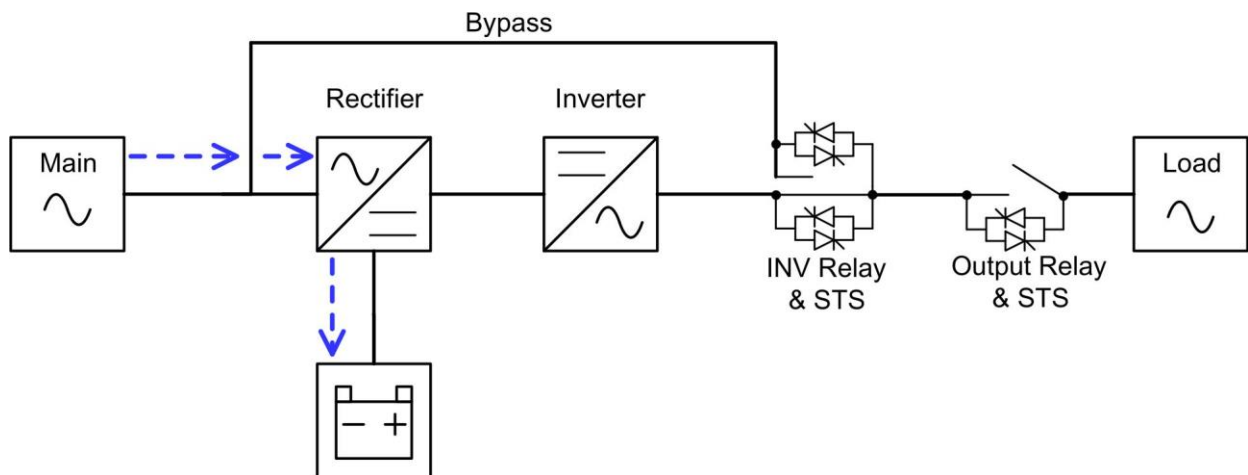

Standby Mode Diagram

### 3-1-3. Bypass Mode

Upon connecting to utility input power, the UPS is in Bypass mode before UPS is turned on (if BYPASS enable setting is Enabled), and charger function will be active when battery is present.

After UPS has been turned on, if the UPS encounters abnormal situations (over-temperature, overload ..., etc.), UPS will perform the load from the inverter to the bypass source with no interruption. If the transference is caused by a recoverable reason, the UPS will turn back to line mode when abnormal situation is solved.

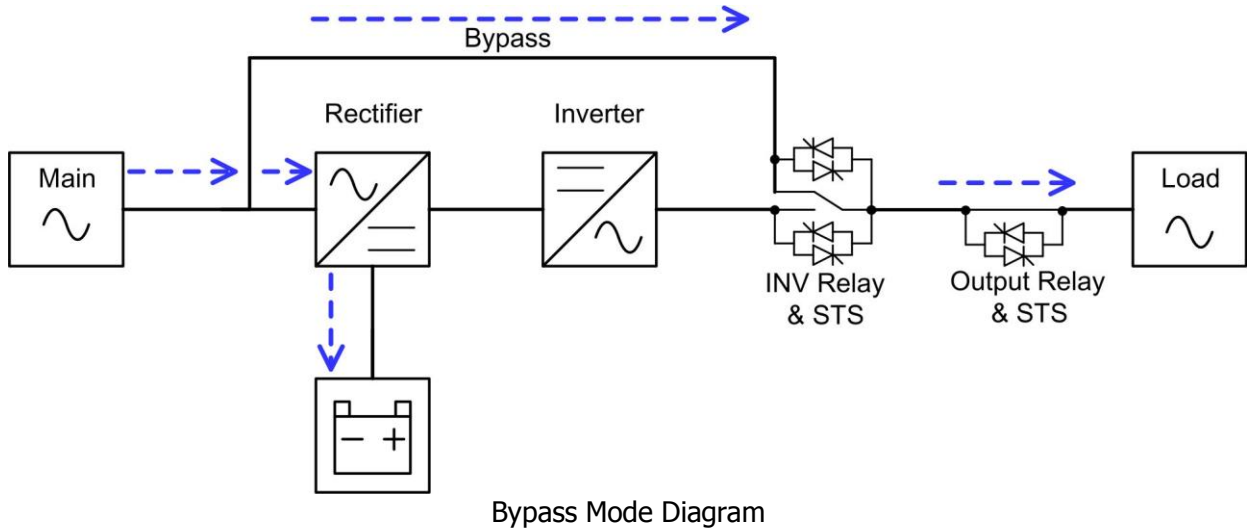

### 3-1-4. Line Mode

In Line Mode, the rectifier derives power from the utility power, supplies DC power to the inverter and the charger charges the battery. The inverter filters the DC power and converts it into pure and stable AC power to the load.

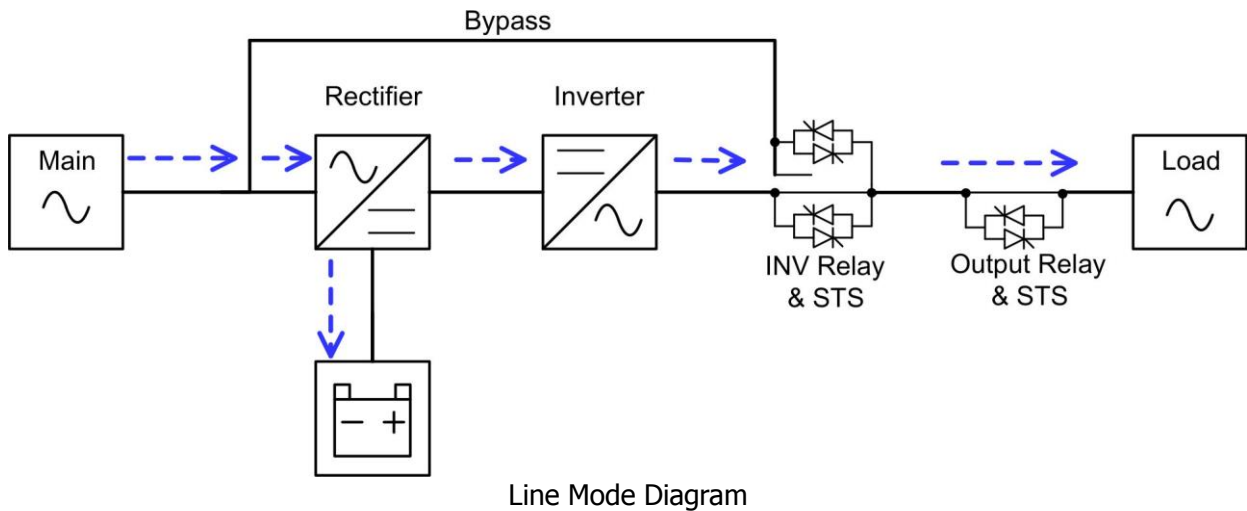

### 3-1-5. Battery Mode

The UPS automatically transfers to battery mode if the utility power fails. There is no interruption in power to the critical load upon failure.

In battery mode, the rectifier derives power from the battery and supplies DC power to the inverter. The inverter filters the DC power and converts it into pure and stable AC power to the load.

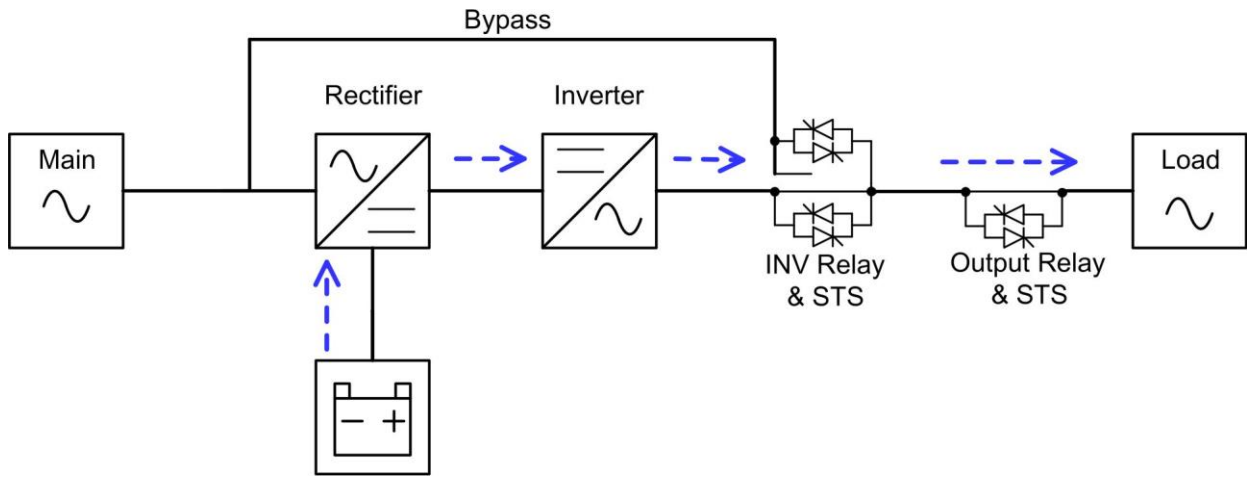

Battery Mode Diagram

### 3-1-6. Battery Test Mode

Users can manually operate UPS to battery test mode. There is no interruption in power to the load. If the test is completed or battery fails, the UPS will return to Line mode or CVCF mode (if CVCF mode is enabled).

In battery test mode, the rectifier derives power from the battery and supplies DC power to the inverter. The inverter filters the DC power and converts it into pure and stable AC power to the load.

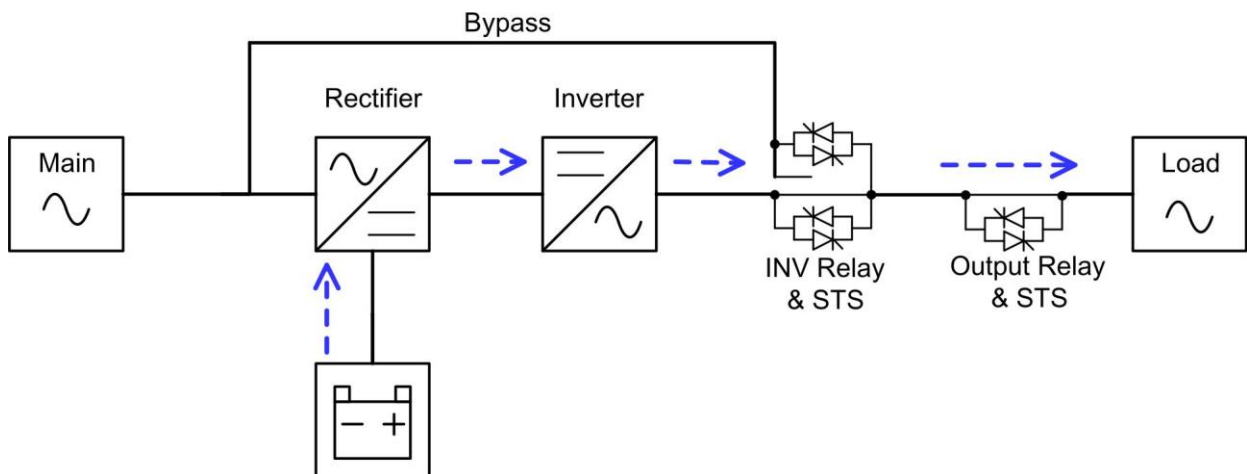

Battery Test Mode Diagram

### 3-1-7. Fault Mode

The UPS transfers to fault mode if the UPS fails.

In fault mode, the charger function will be off and the load is not powered under this mode.

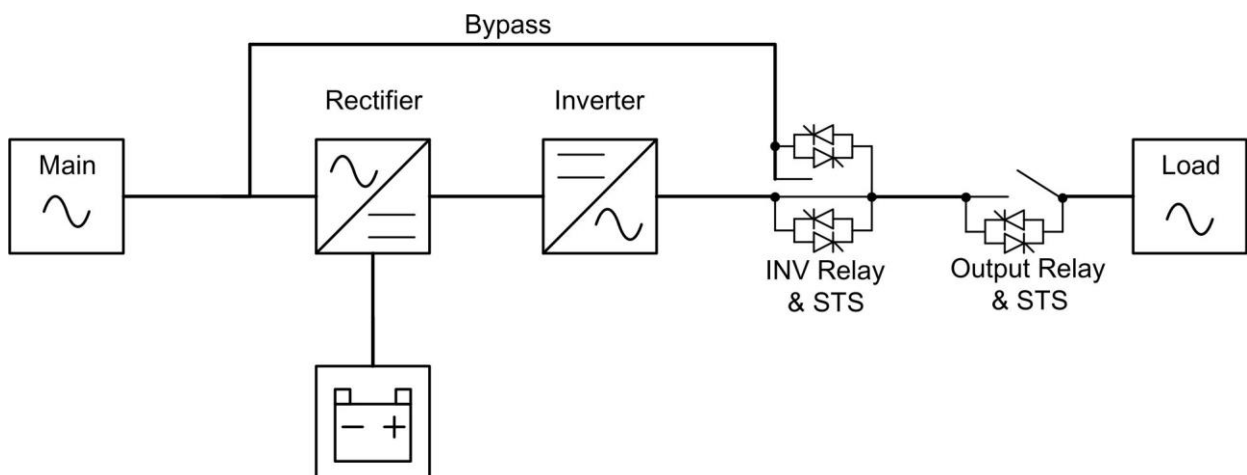

Fault Mode Diagram

### 3-1-8. CVCF Mode

The CVCF mode is enabled through the LCD setting menu. The output frequency will be fixed at 50Hz or 60Hz according to setting of "Freq". In CVCF mode, the rectifier derives power from the utility power, supplies DC power to the inverter and the charger charges the battery. The inverter filters the DC power and converts it into pure and stable AC power to the load.

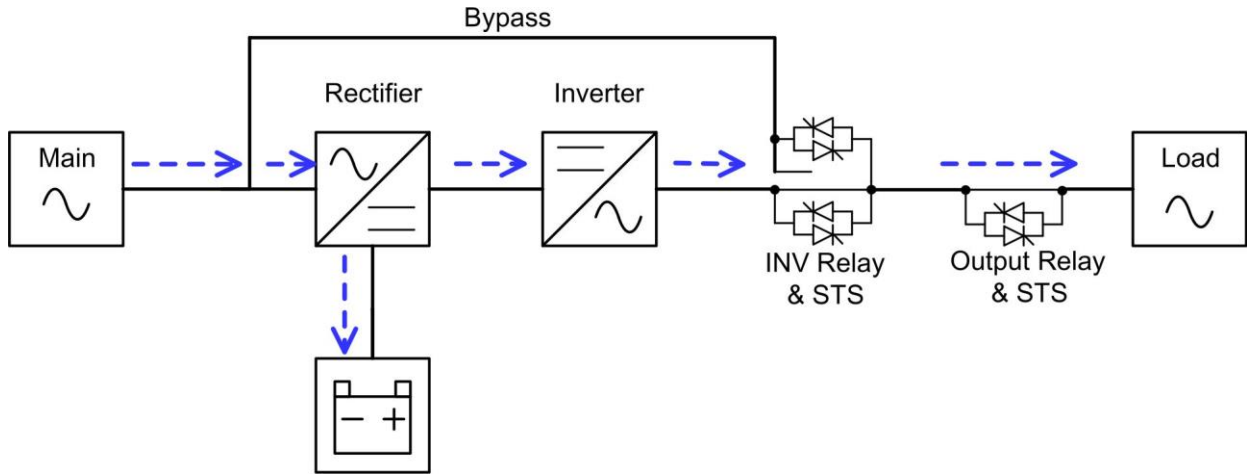

CVCF Mode Diagram

### 3-1-9. ECO Mode

The ECO mode is enabled through the LCD setting menu. In ECO mode, the load is powered by bypass when the bypass voltage and frequency are within the acceptable ranges. If the bypass voltage or frequency is out of range, the UPS will transfer the power source of load from bypass to inverter. In order to shorten the transfer time, the rectifier and inverter are working when the UPS is in ECO mode.

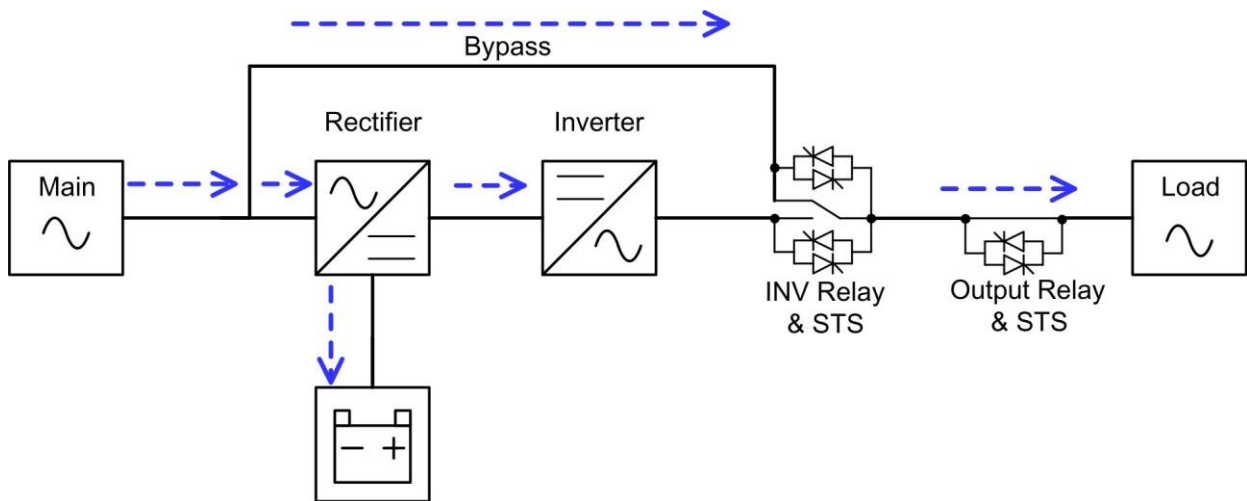

ECO Mode Diagram

### 3-1-10. Shutdown Mode

When the UPS is in the off state and the utility power source is absent, the UPS will enter into shutdown mode.

When the UPS enters this mode, it is going to shut off the control power of UPS. The rectifier, charger and inverter are all in off state.

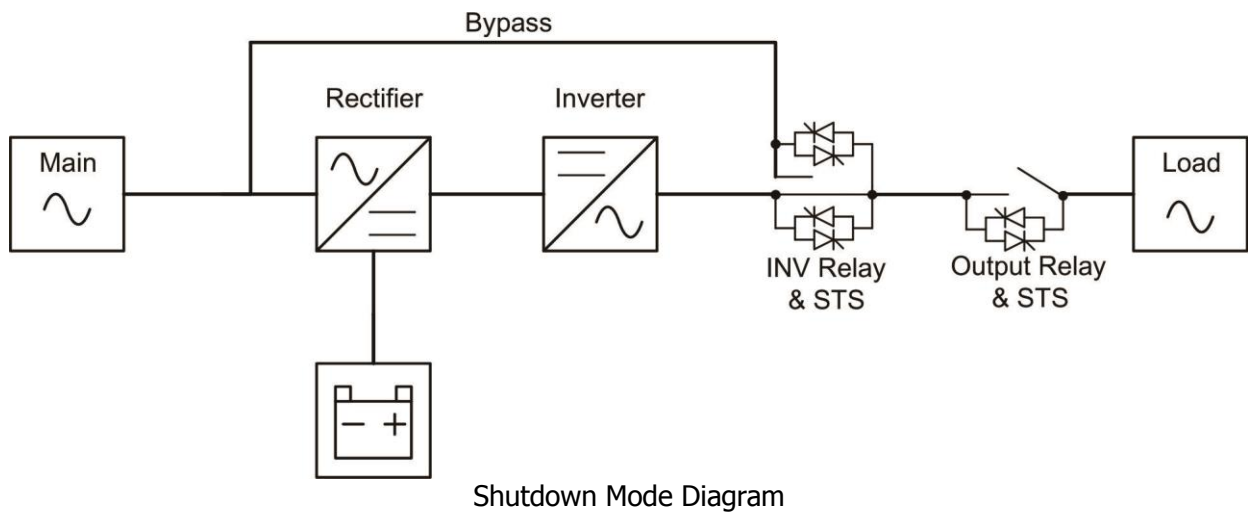

## 3-2. UPS Module Introduction

### 3-2-1. UPS Module

The capacity of each UPS module is 10kVA/10kW for 3-3, 3-1 and 1-1 models, 6kVA/6kW for 2-2 LV model and 10kVA/8kW for 3-3 LV model. No matter what model you purchase, each UPS module should contain a power factor correction rectifier, a battery charger, an inverter, an bypass circuit and control circuit.

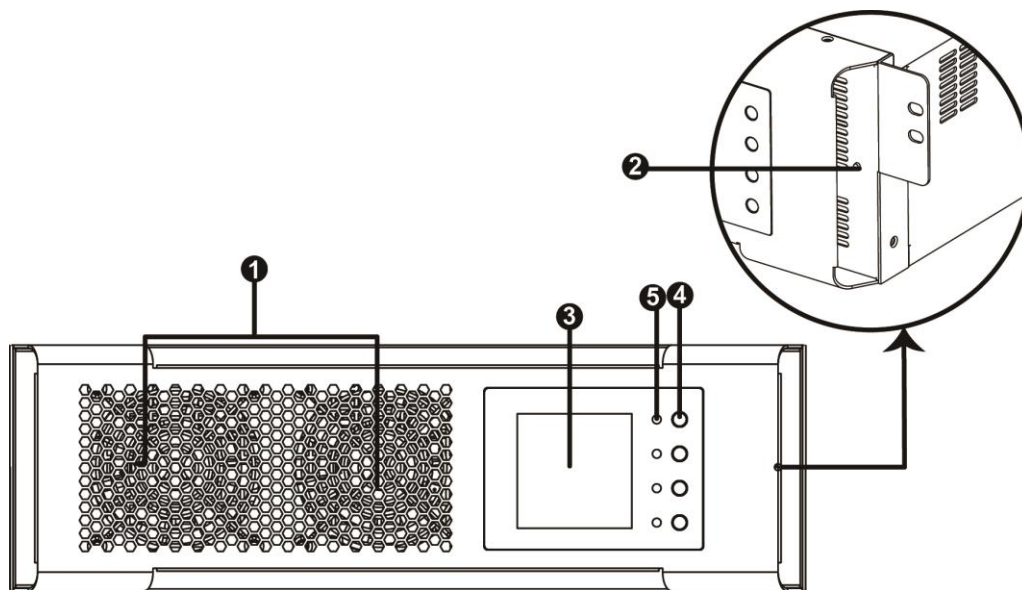

No.	Item	Description
1	Fan	The UPS module uses forced convection cooling by these fans. Cooling air enters the module through ventilation grills and exhalation exhausts through grills located at the rear of the module. Please do not block the ventilation area.
2	Battery Start Button	When AC input is not existing, use this button to start battery power for UPS.
3	LCD display	There is LCD display on the UPS module. It can show the UPS information and the slave UPS information when operating in parallel.
4	Function Keys	There are four function keys in the UPS module. They can control and monitor the single UPS module. Please refer to function key table for the details.
5	LED indicators	There are four LED indicators to show UPS working status. Please refer to LED indicator table for the details.

### 3-2-2. Button Operation

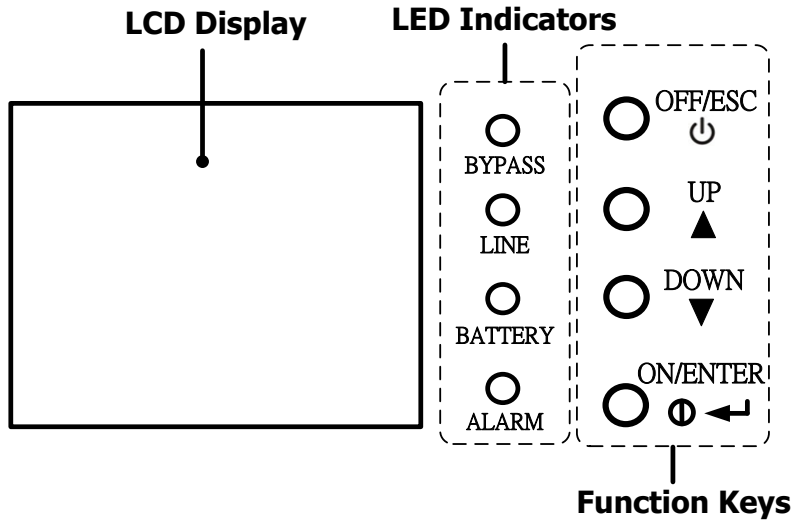

There are four buttons on the front panel.

Control Key	Description
ON/ENTER	<ul style="list-style-type: none"> <li>● Press this button to turn on the UPS.</li> <li>● Or press it to confirm the selection in the menu.</li> </ul>
OFF/ESC	<ul style="list-style-type: none"> <li>● Press this button to turn off the UPS.</li> <li>● Or press it to return to the last menu.</li> </ul>
UP	<ul style="list-style-type: none"> <li>● Press this button to select the previous item in the menu.</li> <li>● Or press this button to jump to previous page in the screen.</li> <li>● Or press this button to increase the number in the setting.</li> </ul>
DOWN	<ul style="list-style-type: none"> <li>● Press this button to select the next item in the menu.</li> <li>● Or press this button to jump to next page in the screen.</li> <li>● Or press this button to decrease the number in the setting.</li> </ul>
UP + DOWN	<ul style="list-style-type: none"> <li>● To allow LCD display to rotate 90 automatically, press these two buttons at the same time. This operation is used to configure the UPS in rack or tower display.</li> </ul>

### 3-2-3. LED Indicators

There are 4 LEDs on front panel to show the UPS working status:

Mode \ LED	BYPASS	LINE	BATTERY	ALARM
UPS Power On	●	●	●	●
Standby mode	○	○	○	○
Bypass mode	●	○	○	○
Line mode / CVCF mode	○	●	○	○
Battery mode	○	○	●	○
Fault mode	○	○	○	●
Battery Test mode	○	●	●	○
ECO mode	●	●	○	○

Note: ● means LED is lighting, and ○ means LED is faded.

### 3-2-4. Audible alarm

UPS status	Buzzer status	Muted
Bypass mode	Beeping once every 2 minutes	Yes
Battery / Battery-test mode (normal battery voltage)	Beeping once every 4 seconds	Yes
Battery / Battery-test mode (low battery voltage)	Beeping once every second	Yes
Fault	Beeping continuously	Yes
Warnings (except overload)	Beeping once every second	No
Overload	Beeping twice every second	No

### 3-3. Single UPS Operation

#### 3-3-1. Turn on the UPS with utility power supply (to Line mode)

- 1) Make sure mains input and battery are connected well, and the Battery pack breaker is at "ON" position; Set the external mains input breaker to "ON" position, then the fan will be running and the UPS supplies power to the loads via bypass; (The UPS is operating in Bypass mode.)  
NOTE: When UPS is in Bypass mode, the output voltage comes directly from utility, so the load is not protected by UPS. To protect the precious load, the UPS should be turned on to Line mode.
- 2) When LCD is on home page, press the "ON/ENTER" button, LCD will show a prompt page of "Turn On"; Move the arrow to "Yes" by up or down button, then press "ON/ENTER", the UPS will be starting up with beeping once. You could also enter the "control menu" to select the instruction "Turn On" to startup the UPS. Please refer to the section of "LCD operation".
- 3) A few seconds later, the UPS will enter into Line mode; "Line mode" will be displayed on LCD. (In line mode, if the utility power is abnormal, the UPS will transfer to Battery mode without interruption.)

#### 3-3-2. Turn on the UPS without utility power supply (to Battery mode)

- 1) Make sure the battery is connected well and the Battery pack breaker is at "ON" position;
- 2) Press the "ON/ENTER" button to start up the internal power, the UPS will enter into bypass mode without output;
- 3) When LCD is on home page, press the "ON/ENTER" button, LCD will show a prompt page of "Turn On"; Move the arrow to "Yes" by up or down button, then press "ON/ENTER", the UPS will be starting up with beeping once. You could also enter the "control menu" to select the instruction "Turn On" to startup the UPS. Please refer to the section of "LCD operation".
- 4) A few seconds later, the UPS will enter into Battery mode; "Battery mode" will be displayed on LCD (In Battery mode, it will shutdown automatically when battery is depleted. If the utility power is restored, it will auto restart to Line mode.)

#### 3-3-3. Connect devices to UPS

After the UPS is turned on, you can connect devices (load) to the UPS.

- 1) Turn on the UPS first and then switch on the devices one by one, the LCD panel will display total load level;
- 2) If inductive loads needed to be connected, such as a printer, the in-rush current should be calculated carefully to see if capacity of the UPS can cover due to the huge starting power consumption of this kind of load;
- 3) If the UPS is overload, the buzzer will beep twice every second;
- 4) When the UPS is overload, please remove some loads immediately. It is recommended to have the

total loads connected to the UPS less than 80% of its nominal power capacity for system safety;

- 5) If the overload time is over duration listed in spec at Line mode, the UPS will automatically transfer to Bypass mode. After the overload is removed, it will return to Line mode. If the overload time is over duration listed in spec at Battery mode, the UPS will become fault status. At this time, if bypass is enabled, the UPS will power to the load via bypass. If bypass function is disabled or the input power is not within bypass acceptable range, it will cut off output directly.

#### **3-3-4. Charge the batteries**

- 1) After the UPS is connected to the utility power, the charger will charge the batteries automatically except in Battery mode or during battery test;
- 2) Suggest to charge batteries at least 10 hours before use. Otherwise, the backup time may be shorter than expected;
- 3) Make sure the battery numbers setting on the LCD Panel (Please refer to the section of changing battery quantity) is consistent with actual connection.

#### **3-3-5. Battery mode operation**

- 1) When the UPS is in Battery mode, the buzzer will beep according to different battery capacity. Normally, the buzzer will beep once every 4 seconds in battery mode, but when the battery voltage drops to the alarm level, the buzzer will beep once per second and the UPS will shut down automatically soon. Users could switch off some non-critical loads to disable the shutdown alarm and prolong the backup time. If there is no more load to be taken off at that time, you have to shut down all loads as soon as possible to protect the devices or save data. Otherwise, there is a risk of data loss or load failure.
- 2) In Battery mode, if buzzer sounds annoying, you could enter "Control->Mute" on LCD to silence it. Please refer to the section of "LCD operation".
- 3) The backup time of the long-run model depends on the external battery capacity.
- 4) The backup time may change under different environment temperature and load type.
- 5) The maximum backup time is limited by default 16.5 hours (After discharging 16.5 hours, UPS will shut down automatically to protect the battery). The time could be modified through LCD panel or communication port.

#### **3-3-6. Test the batteries**

- 1) If you need to check the battery status or performance when the UPS is running in Line / Converter (CVCF) / ECO mode, you could enter "Control->Bat Test" to instruct the UPS to do battery test. Please refer to the section of "LCD operation";
- 2) Users also can set battery test through monitoring software;
- 3) If the UPS is in battery testing, "Battery test mode" will be displayed on LCD, the buzzer indication will be the same as Battery mode, but both line LED and battery LED will be lit.

#### **3-3-7. Turn off the UPS with utility power supply in Line mode**

- 1) When LCD is on home page, press the "OFF/ESC" button, LCD will show a prompt page of "Turn Off"; Move the arrow to "Yes" by up or down button, then press "ON/ENTER", the UPS will be turning off to bypass mode with beeping once. You could also enter the "control menu" to select the instruction "Turn Off" to turn off the UPS. Please refer to the section of "LCD operation";

**NOTE:** Here, "Turn Off" means that UPS is not working on line / converter / ECO / battery / battery test mode. So even though the UPS is turned off, if input or bypass voltage is normal, the internal power supply will be still working; and if bypass status has been set to "enable", the output voltage of the UPS will be still exist;



- 2) If you need to fully cut off the output, please switch off the external input breaker. A few seconds later, there is no display shown on the panel and UPS is completely off.

### **3-3-8. Turn off the UPS without utility power supply in Battery mode**

- 1) When LCD is on home page, press the "OFF/ESC" button, LCD will show a prompt page of "Turn Off"; Move the arrow to "Yes" by up or down button, then press "ON/ENTER", the UPS will be turning off to bypass mode with beeping once. You could also enter the "control menu" to select the instruction "Turn Off" to turn off the UPS. Please refer to the section of "LCD operation";
- 2) If there is no bypass input voltage, the UPS will cut off all power supply and there is no display shown on the panel.

### **3-3-9. Operation of changing battery quantity (number)**

The default battery (12V) quantity of this UPS system is 16 (for one series), but 17, 18, 19, 20 could also be applied in this system. Changing the battery quantity setting, can setup from UPS LCD panel.

NOTE: This operation should be done by professional technicians, please contact the dealer for support

### 3-4. LCD Operation on UPS Module

#### 3-4-1. LCD Structure

The entire LCD structure is demonstrated as diagram below.

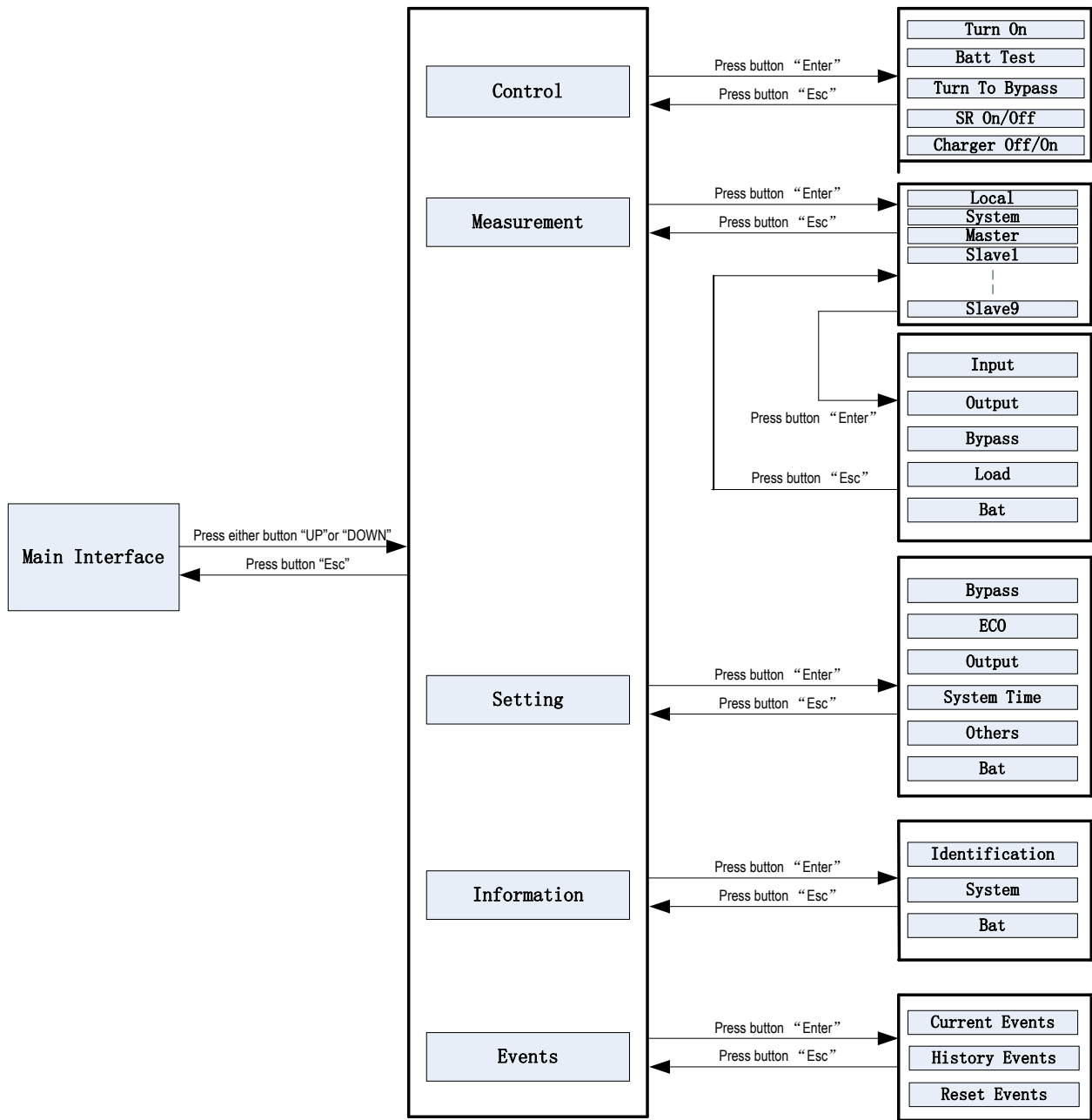

LCD Structure

### 3-4-2. Main interface (Home Page)

After initialization, the main screen will display as below chart.

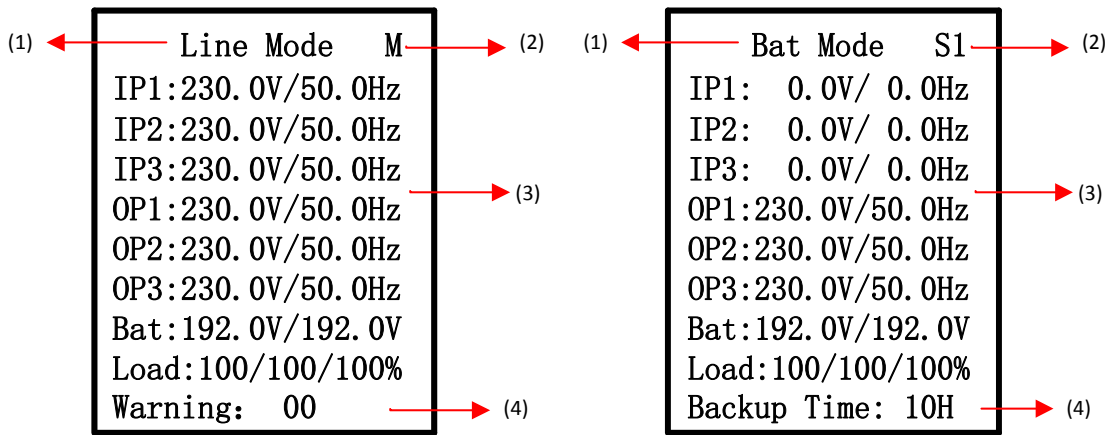

Main screen (Home Page)

- 1) UPS Mode: Current operation mode.
- 2) It will display the UPS running status mode and parallel information as below table.

Short Description	Description
N	New adding module into parallel system.
M	Master
S<n>	Slave, <n> means the number of slave module.

- 3) Input and output information.
- 4) Battery capacity, load level and backup time/warning or fault codes. When alarms happen, the warning or fault information will display. When UPS is operated in Battery mode or Battery Test mode, the backup time will display.

When the front panel is not operated for 2 minutes, the display page will return back to home page. Press the "UP" or "DOWN" button to enter the operation menu (Refer to 4.2.3).

When it displays home page in LCD, if UPS is in bypass or standby, you could press the "ON/ENTER" button to turn on the UPS to line / CVCF / ECO / battery mode according to the setting and input status.

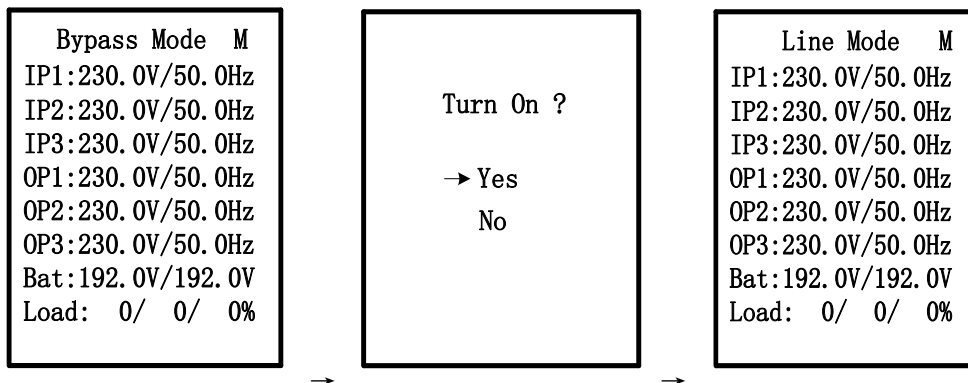

When UPS is turned on, you could press the "OFF/ESC" button to allow UPS to bypass mode or standby.

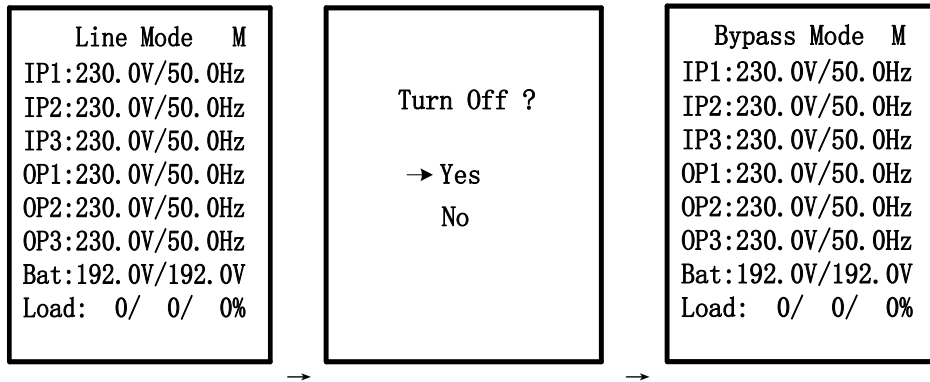

### 3-4-3. Operation menu

#### 3-4-3-1. Main menu

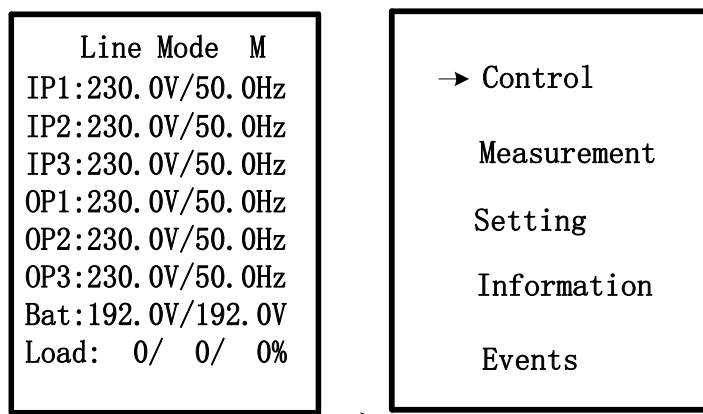

Main screen(Home page) → Main menu

- 1) After pressing the "UP" or "DOWN" button on the main screen (Home page), it will display five items in operation menu: Control / Measurement / Setting / Information / Events.
- 2) Press "UP" or "DOWN" button to select item.
- 3) Press "ON/ENTER" button to confirm the selection.
- 4) Press "OFF/ESC" button to return back to main scree (Home page).

#### 3-4-3-2. Control

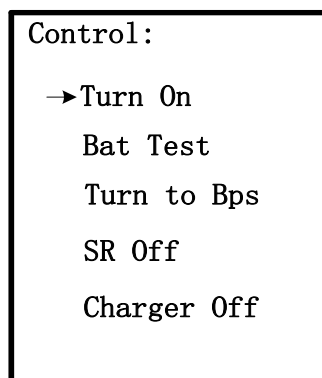

In "Control" screen, it's real-time command for UPS.

- "Turn On" will be displayed if UPS is not turned on. "Turn Off" will be displayed if UPS is turned on.
- "Bat Test" will be displayed if UPS is not in Battery Test Mode. "Cancel Test" will be displayed if UPS is in Battery Test Mode.
- "Turn to Bps" will be displayed all the time no matter what status UPS is. But this action is only effective when the input power is available.

- "SR Off" will be displayed if UPS is not turned on. "SR On" will be displayed if UPS is turned on.
- "Charger Off" will be displayed if charger is working. "Charger On" will be displayed if charger is turn off.

Generally speaking, only one selection will be displayed in the screen and it depends on UPS status.

### 1) Turn On/Turn Off

This item is for turning on/off the UPS.

- a) On Bypass mode or Standby mode, it will display "Turn On" in control menu. If it is selected and confirmed, the UPS will transfer to line mode, CVCF mode, ECO mode, or battery mode according to the setting and input status.

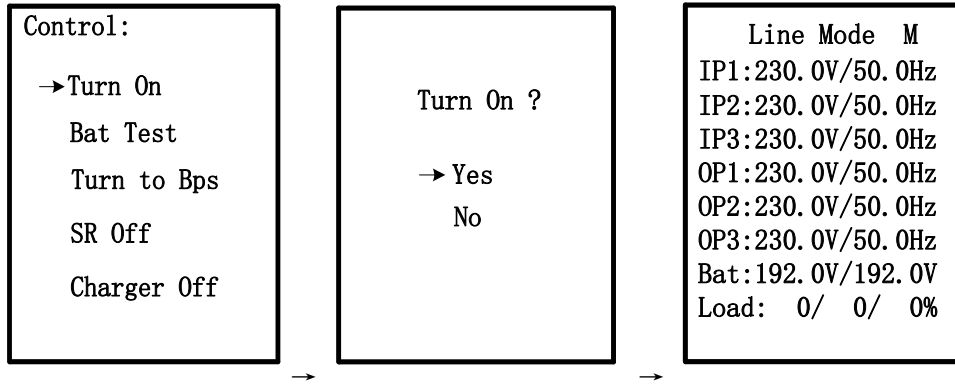

**NOTE:** You may simply turn on UPS by pressing "ON/ENTER" button in main scree (Home page). It's not necessary to enter control menu to turn on the UPS.

- b) On line mode, CVCF mode, ECO mode or battery mode, it will display "Turn Off" in control menu. If it is selected and confirmed, the UPS will transfer to bypass mode or standby mode.

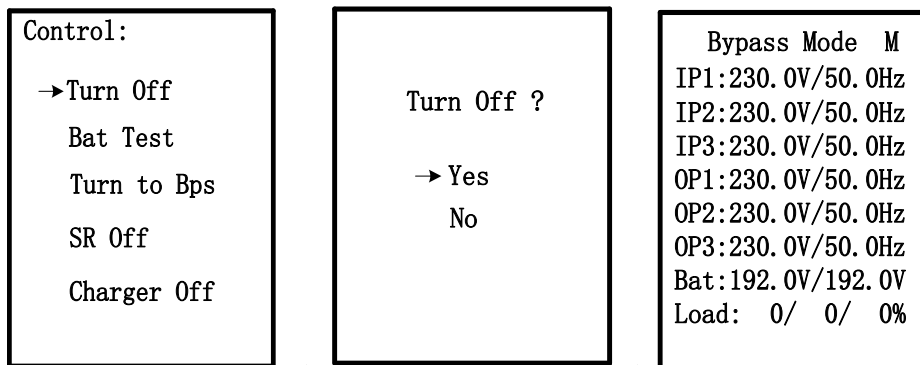

**NOTE:** You may simply turn off UPS by pressing "OFF/ESC" button in main scree (Home page). It's not necessary to enter control menu to turn off the UPS.

### 2) Battery Test / Cancel Test

- a) It is to check if the UPS could work well in battery mode and test the battery performance. Except UPS is in Battery Test mode, "Battery Test" selection will be displayed under all operation modes.

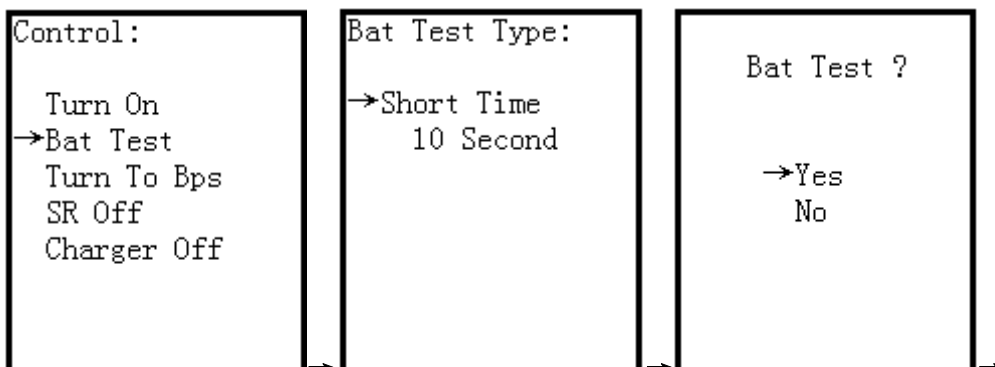

```

Bat Test Mode M
IP1:230.0V/50.0Hz
IP2:230.0V/50.0Hz
IP3:230.0V/50.0Hz
OP1:230.0V/50.0Hz
OP2:230.0V/50.0Hz
OP3:230.0V/50.0Hz
Bat:192.0V/192.0V
Load: 0/ 0/ 0%
Backup Time: 10H

```

However, it could execute this test in Line/Converter mode and reminder will pop up in the screen. When "Yes" is selected, the screen will return back to home page with "Battery Test Mode" displayed on top. If the test is completed, the displayed status will change back to UPS current mode. There are four battery test types to select. Refer to below table.

**Table: Battery Test Type**

Setting Item	Sub Item	Explanation
Battery Test Type	Short Time	10-second test time.
	Long Time	When testing time is longer than 1 minute, please select "Long Time" and the duration is able to set up. (1~99min) ● 10 min (Default)
	Till to Bat Low	Test until the battery is low voltage.

- b) On Battery Test mode, it will display "Cancel Test" in control menu. When "Cancel Test" is selected, the screen will change back to UPS current mode.

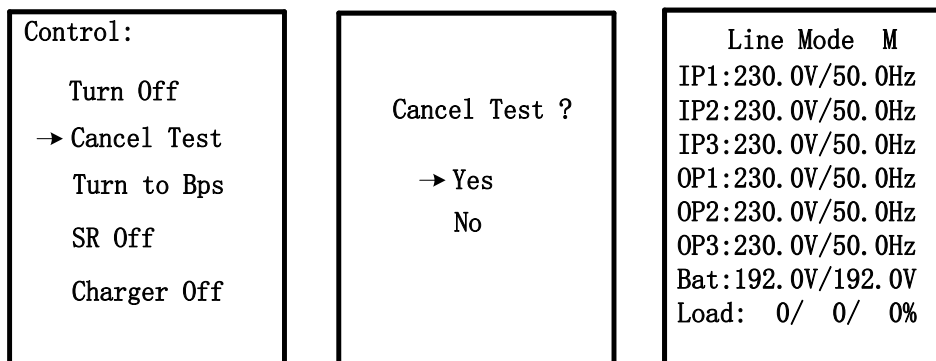

### 3) Turn to Bypass

If it is selected and confirmed, the UPS will transfer from Line mode to Bypass mode.

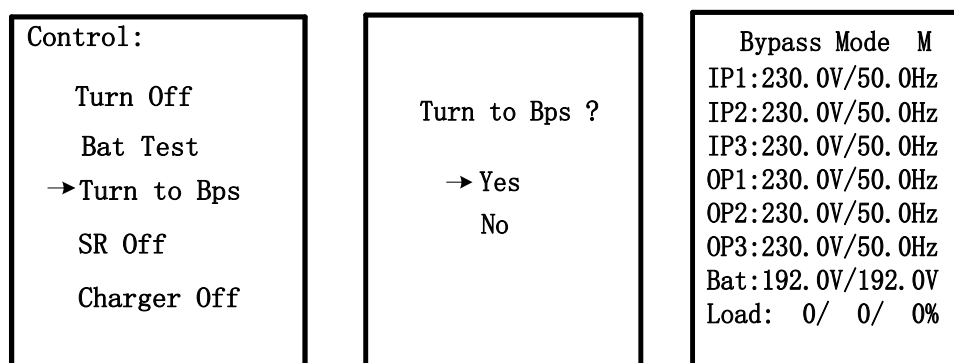

**4) SR On / SR Off**

- a) On Line/Battery/Battery Test/CVCF/ECO mode, it will display "SR On" in control menu. If it is selected and confirmed, shutdown and restore time can be setting. Please refer to setting range table for shutdown and restore time.

When "Shutdown Time" countdown ends, the UPS will turn off. Then, the "Restore Time" will start to count. When countdown ends, the UPS will be turned on and back to current mode.

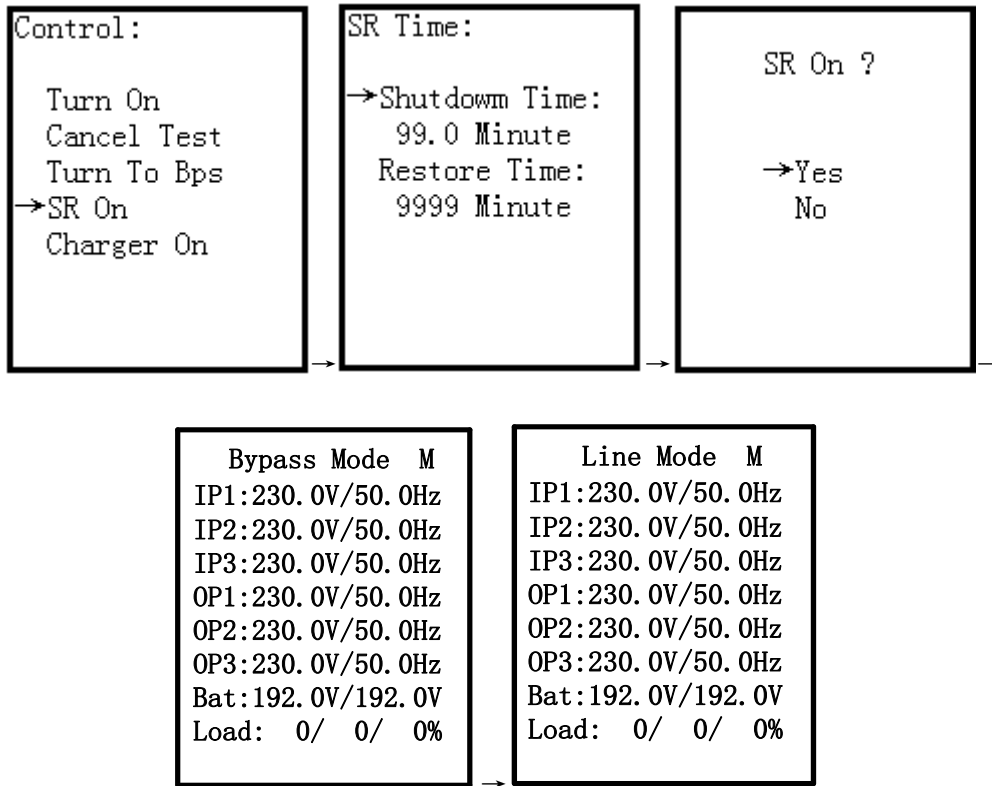

**Table:** Setting range for Shutdown & Restore Time

Setting Item	Sub Item	Explanation
SR On/SR Off	Shutdown Time	Set system shutdown time (0.2~99min) ● 0.2 min (Default)
	Restore Time	Set system restore time (0~9999min) ● 1 min (Default)

- b) On Standby/Bypass/Fault mode, it will display "SR Off" in control menu. If it is selected and confirmed, the screen will return back to home page and system will back to current mode. If "SR On" is selected and confirmed, When UPS in Line/Battery/Battery Test/CVCF/ECO mode, it will display "SR Off" in control menu. If it is selected and confirmed, the screen will return back to home page and system will cancel this function.

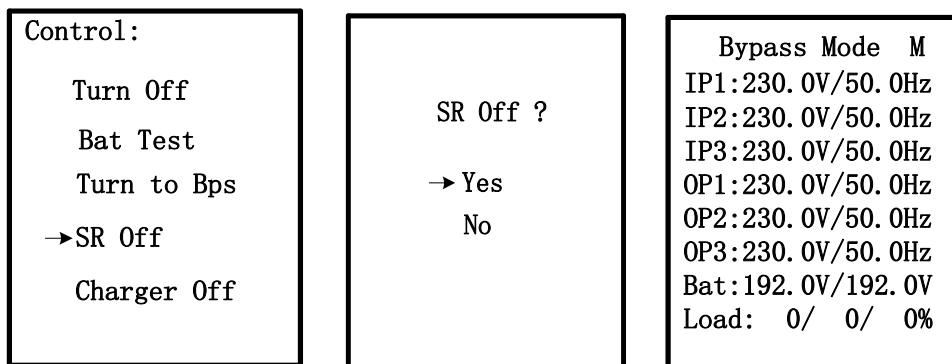

### 5) Charger Off / Charger On

- a) This selection will be displayed under all UPS modes when charger is working. If it is selected and confirmed, the screen will return back to home page. And charger will stop charging the battery.

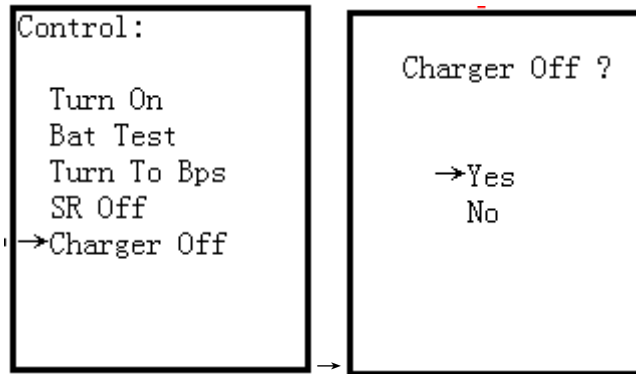

- b) This selection will be displayed under all UPS modes when charger is turned off. If it is selected and confirmed, the screen will return back to home page. And charger will charging the battery.

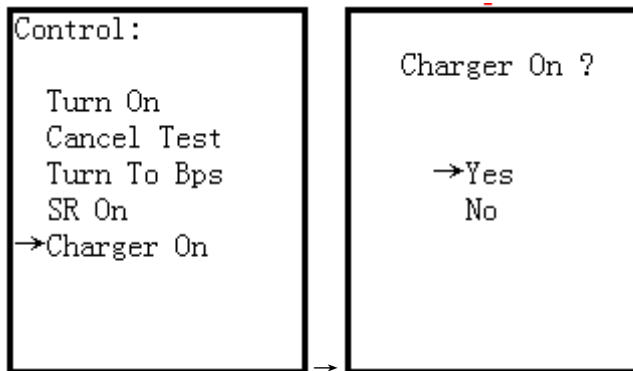

### 3-4-3-3. Measurement

Measurement displays the measurement value of the parameters such as voltage / current / frequency / power / capacity / time etc. Each UPS could display the measured value of the whole system. Press "▲" or "▼" button to explore the pages.

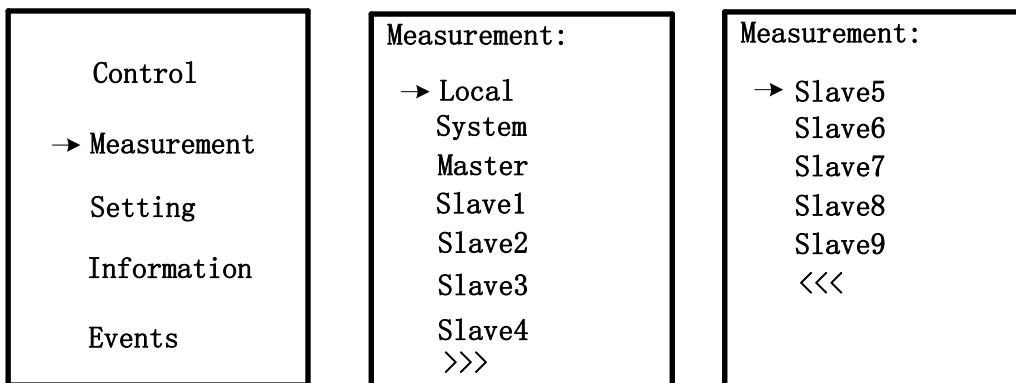

"Local" means the current UPS module. "System" means all UPS modules. "Master" and "Slave<n>" means the other UPS module in this parallel system.



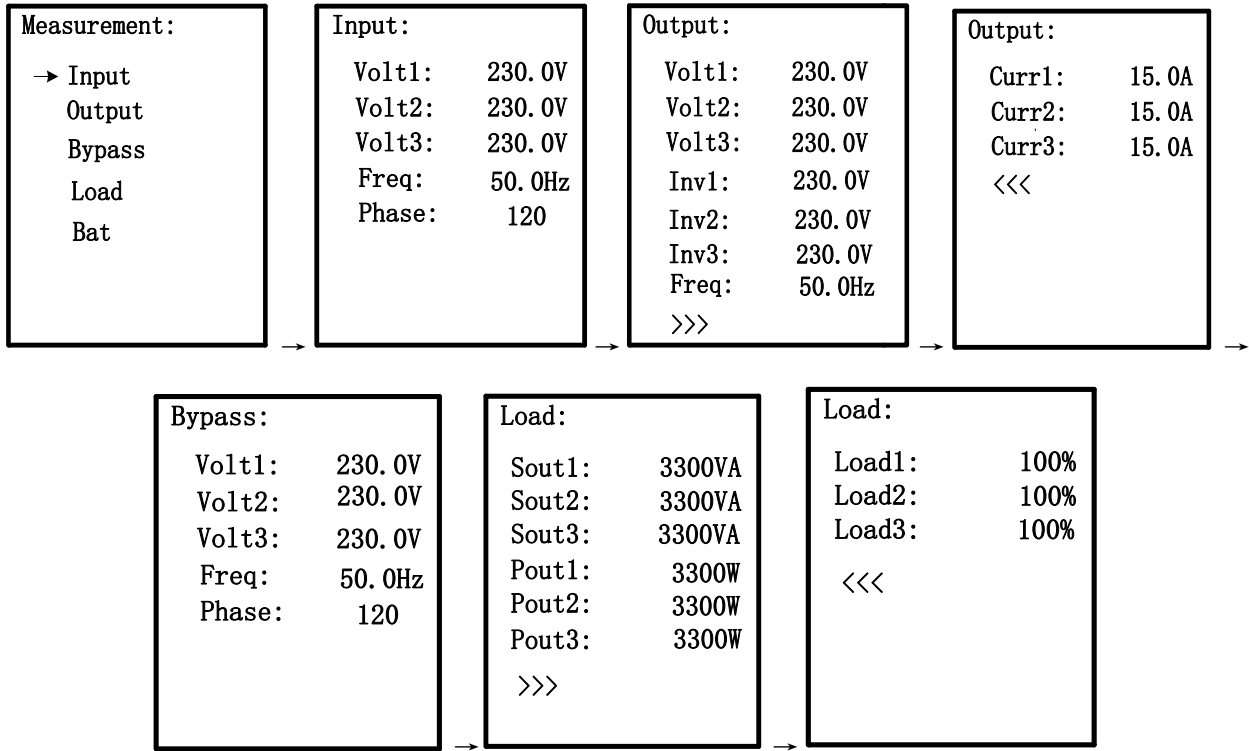

### 3-4-3-4. Setting

This page is used to configure the parameter settings. It's necessary to enter password to enter submenus. The default password is 0729. There are submenus under the Setting, including Bypass, ECO, Output, SystemTime, Others and Battery, as shown below.



**NOTE:** Some settings will be only available in some operation modes. If the setting is not available in current mode, the LCD will show prompt message with "Item can't be set in this mode". Press any button or just wait for several seconds until this message fades.

**1) Bypass setting** (only available or effective on bypass mode and standby mode)

Interface	Description
<div style="border: 1px solid black; padding: 5px; width: fit-content;"> <p>Bypass:</p> <p>Status:           Open                           Disable</p> <p>HighLoss V:  240V</p> <p>LowLoss  V:  110V</p> <p>HighLoss F:  54Hz</p> <p>LowLoss  F:  46Hz</p> </div>	<p><b>1. Status</b></p> <p><b>1.1 Open/Forbid:</b></p> <p><b>Open:</b> Bypass allowed. When selected, UPS will run at Bypass mode depending on bypass enabled/disabled setting.</p> <p><b>Forbid:</b> Bypass not allowed. When selected, it's not allowed for running in Bypass mode under any situations.</p> <p>The default setting is <b>Open</b>.</p> <p><b>1.2 Enable/Disable</b></p> <p>This option appears only when Bypass status is set to "Open".</p> <p><b>Enable:</b> Bypass enabled. When selected, Bypass mode is activated.</p> <p><b>Disable:</b> Bypass disabled. When selected, automatic bypass is acceptable, but "manual bypass" is not available. "Manual bypass" means users manually operate UPS to Bypass mode (for example, in AC mode turning off the UPS to Bypass mode). Then, the UPS will go to bypass mode but without output if it is turned off in AC mode.</p> <p>The default setting is <b>Enable</b>.</p> <p><b>NOTE:</b> The following items are only available in bypass mode.</p> <p><b>2. HighLoss V:</b> Set the acceptable high voltage for bypass. Setting range is from (Rated Output Volt +11V) to 276V and the default value is 264V.</p> <p><b>3. LowLoss V:</b> Set the acceptable low voltage for bypass. Setting range is from 110V to (Rated Output Volt - 11V) and the default value is 110V.</p> <p><b>4. HighLoss F:</b> Set the acceptable high frequency for bypass.</p> <p>50 Hz system: Setting range is from 51Hz to 54 Hz.</p> <p>60 Hz system: Setting range is from 61Hz to 64Hz.</p> <p>The default value is 54.0Hz/64.0Hz.</p> <p><b>5. LowLoss F:</b> Set the acceptable low frequency for bypass.</p> <p>50 Hz system: Setting range is from 46.0Hz to 49.0Hz.</p> <p>60 Hz system: Setting range is from 56.0Hz to 59.0Hz.</p> <p>The default value is 46Hz/56Hz.</p>

**2) ECO setting** (only available or effective on bypass mode, standby mode, Line mode and ECO mode)

Interface	Description
<div style="border: 1px solid black; padding: 5px; width: fit-content;"> <p>ECO:</p> <p>Status:   Disable</p> <p>HighLoss V:  240V</p> <p>LowLoss  V:  218V</p> <p>HighLoss F:  52Hz</p> <p>LowLoss  F:  48Hz</p> </div>	<p><b>1. Status</b></p> <p><b>Enable:</b> ECO function enabled</p> <p><b>Disable:</b> ECO function disabled</p> <p>If ECO function is disabled, voltage range and frequency range for ECO mode still can be set, but it is meaningless unless the ECO function is enabled. The default setting is <b>Disable</b>.</p> <p><b>2. HighLoss V:</b> High voltage point in ECO mode. The setting range is from (Rated Output Volt +11V) to (Rated Output Volt +24V) and the default setting is (Rated Output Volt +11V).</p> <p><b>3. LowLoss V:</b> Low voltage point in ECO mode. The setting range is from (Rated Output Volt -24V) to (Rated Output Volt-11V) and the default setting is (Rated Output Volt -11V).</p> <p><b>4. HighLoss F:</b> Set High frequency point for ECO mode.</p> <p>50 Hz system: Setting range is from 52Hz to 54Hz.</p> <p>60 Hz system: Setting range is from 62Hz to 64Hz.</p> <p>The default value is 52Hz/62Hz.</p> <p><b>5. LowLoss F:</b> Set Low frequency point for ECO mode.</p> <p>50 Hz system: Setting range is from 46Hz to 48Hz.</p> <p>60 Hz system: Setting range is from 56Hz to 58Hz.</p> <p>The default value is 48Hz/58Hz.</p>

**3) Output setting** (only available or effective on bypass mode and standby mode)

Interface	Description
<div style="border: 1px solid black; padding: 10px; width: fit-content;"> <pre>Output: Volt:      230V Freq:      60Hz CVCF:      Enable</pre> </div>	<p><b>1. Volt:</b>  <b>208:</b> Presenting the rated output voltage with 208Vac  <b>220:</b> Presenting the rated output voltage with 220Vac  <b>230:</b> Presenting the rated output voltage with 230Vac  <b>240:</b> Presenting the rated output voltage with 240Vac  The default value is <b>230Vac</b>.</p> <p><b>2. Freq:</b>  <b>50Hz:</b> The output frequency is setting for 50Hz.  <b>60Hz:</b> The output frequency is setting for 60Hz.  <b>NOTE:</b> CVCF should be enabled first to modify this item.  If CVCF is disabled, output frequency will be decided according to the latest normal utility frequency. If it is within 46Hz and 54Hz, the output frequency will be 50.0Hz. If it is within 56Hz to 64Hz, the output frequency will be 60.0Hz.</p> <p><b>3. CVCF:</b>  Enable or disable CVCF (converter) mode.  <b>Enable:</b> The output frequency will be fixed at 50Hz or 60Hz according to setting of "Freq". The input frequency could be from 46Hz to 64Hz.  <b>Disable:</b> The output frequency will synchronize with the input frequency within 46~54 Hz for 50Hz system or within 56~64 Hz for 60Hz system.  <b>NOTE:</b> CVCF means Constant Voltage and Constant Frequency. It represents converter mode.  The default setting is <b>Disable</b>.</p>

**4) SystemTime setting** (available or effective on all mode)

Interface	Description
<div style="border: 1px solid black; padding: 10px; width: fit-content;"> <pre>SystemTime: →2016-04-26   11:10:26   Tuesday</pre> </div>	<p><b>SystemTime:</b>  Date, time and calendar date can be modified via this interface. Input the actual time, the unit will automatically adjust timer after "←" button is pressed.</p>

**5) Others setting**

Interface	Description
<div style="border: 1px solid black; padding: 10px; width: fit-content;"> <pre>Others: →Hot Standby:       Disable Audible Mute:       Disable Language:       English &gt;&gt;&gt;</pre> </div>	<p><b>1. Hot standby</b>(only available or effective on bypass mode and standby mode):  <b>Enable:</b> Hot standby function is enabled. It means that the current UPS is set to be host of hot standby system, and it will automatically restart after AC recovery even without battery connected.  <b>Disable:</b> Hot standby function is disabled. The UPS is running at normal mode and can't restart without battery.  The default setting is <b>Disable</b>.</p> <p><b>2. Audible Mute</b>(available or effective for all mode):  <b>Enable:</b> It is to mute the buzzer.  <b>Disable:</b> It is to enable the buzzer when UPS have alarms or UPS is working in bypass mode or battery mode.  The default setting is <b>Disable</b>.</p> <p><b>3. Language</b> (available or effective for all mode):  <b>English:</b> All interface will show in English</p>

<pre> Others: →Bat Mute:     Disable Fault Mute:     Disable Bypass Mute:     Disable &gt;&gt;&gt; </pre> <pre> Others: →Redundancy: 00 Total Power: 02 Standard Mode:     Enable Factory Reset &lt;&lt;&lt; </pre>	<p><b>4. Bat Mute</b>(available or effective on all mode):  <b>Enable:</b> It is to mute the buzzer when UPS is in battery mode.  <b>Disable:</b> It is to enable the buzzer when UPS is in battery mode.  The default setting is <b>Disable</b>.</p> <p><b>5. Fault Mute</b>(available or effective on all mode):  <b>Enable:</b> It is to mute the buzzer when UPS is in fault mode.  <b>Disable:</b> It is to enable the buzzer when UPS is in fault mode.  The default setting is <b>Disable</b>.</p> <p><b>6. Bypass Mute</b>(available or effective on all mode):  <b>Enable:</b> It is to mute the buzzer when UPS is in bypass mode.  <b>Disable:</b> It is to enable the buzzer when UPS is in bypass mode.  The default setting is <b>Disable</b>.</p> <p><b>7. Redundancy</b> (available or effective on all mode): It is to set the quantity of redundant UPS module. The setting range is 0~9. The setting quantity must be less than the total number of UPS modules in the system. The default value is 0.</p> <p><b>8. Total Power</b> (available or effective on all mode): It is to set parallel number of power modules for whole system.</p> <p><b>9. Standard Mode</b>(only available or effective on bypass mode and standby mode):  <b>Enable:</b> It is a compatible mode for dynamo.  <b>Disable:</b> It is a normal mode.  The default setting is <b>Enable</b>.</p> <p><b>10. Factory Reset</b>(only available or effective on bypass mode and standby mode): Restore to factory default setting.</p>
---	--

## 6) Battery

Interface	Description
<pre> Bat: →DisChg Protect:     Enable Backup Time:     990 Minute Cold Start:     Enable Charger Test &gt;&gt;&gt; </pre> <pre> Bat: →Low Volt: 11.2V UnderVolt:10.7V Periodic Test:     Enable Periodic Time:     30 Day &gt;&gt;&gt; </pre>	<p><b>1. Dischg Protect:</b> Enable or disable battery discharge protection.  <b>Enable:</b> Battery discharge protection function is enabled. When UPS have been continuously working in "battery/battery test mode", the UPS will automatically shut down when the backup time set next is achieved.  <b>Disable:</b> Battery discharge protection function is disabled.  <b>Backup Time:</b> When discharge protection is enabled, this setting time can be counted.  <b>1~990:</b> The maximum discharge time can be set from 1 to 990 minutes. UPS will shut down to protect battery after backup time arrives when the "Dischg Protect" is enabled. If "Dischg protect" is disabled, then this setting does not make sense whatever the value is. The default value for this setting is 990 minutes.</p> <p><b>2. Cold Start:</b>  <b>Enable:</b> UPS could be turned on without mains.  <b>Disable:</b> UPS could not be turned on without mains.</p> <p><b>3. Charger Test:</b>  Test the battery charger even without battery. After entering this item, it will pop up a screen showing "Yes" and "No". If selecting "Yes", the UPS will execute charger test. After test, the LCD screen will return to main scree (home page) and show battery voltages on BAT+ and BAT-.</p> <p><b>4. Low Volt:</b>  Set battery low warning voltage. The setting range is from 10.5~11.5V per piece and the default value is 11.2V.</p> <p><b>5. Under Volt:</b>  Set battery low cut off voltage. The setting range is from 9.6~10.7V per piece and the default value is 9.6V.</p> <p><b>6. Periodic Test:</b>  <b>Enable:</b> UPS will test the battery periodically;  <b>Disable:</b> UPS will not test the battery periodically.</p>

<pre> Bat: →BatNum:      16   ChgCur:     04A   BatGroups:   01   BatCap:      9AH   Factor:      1.0   &lt;&lt;&lt; </pre>	<p><b>7. Periodic Time:</b> When periodic test is enabled, please set up battery test interval. The setting range is from 7 days to 99 days. The default value is 30-day.</p> <p><b>8. BatNum:</b> Set battery number in the system. The setting range is from 16 to 20 pieces. The default value is 16.</p> <p><b>9. Chg Curr:</b> Set maximum charge current. The setting range is from (0~ 4A) x N. N represents the parallel unit number. The default value is 4A. If parallel unit number is 10, the maximum setting value can be 40A.</p> <p><b>10. Bat Groups:</b> Set the number of battery group ranging from 1 to 10. The default value is 1 group.</p> <p><b>11. Bat Cap:</b> Set the battery capacity such as 7AH, 9AH, 10AH, 12AH, 17AH, 26AH, 40AH, 65AH, 100AH and so on. The default value is 9AH.</p> <p><b>12. Factor:</b> Calibrate the displayed backup time by adjusting this multiplier factor. The formulation is listed below: Displayed backup time=Original calculated backup time x Multiplier factor The value of default factor is 1.0. The setting range is from 0.5 to 2.</p> <p><b>Item 10~12 are used for the battery backup time calculation.</b></p>
---	---

### 3-4-3-5. Information

In Information page, you can check the serial number, firmware versions, system configuration and settings of the UPS. There are submenus under the Information, including Identification, System and Battery, as shown below. Information displays all parameter setting value and status.

- 1) Identification item shows the UPS Module name, serial no, UPS display version, controller module version, CPU version and system LCD version.

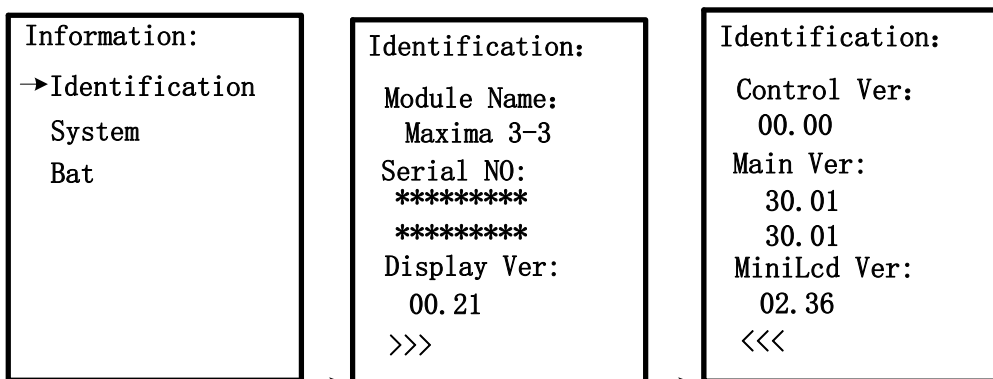

- 2) System shows the UPS configuration.

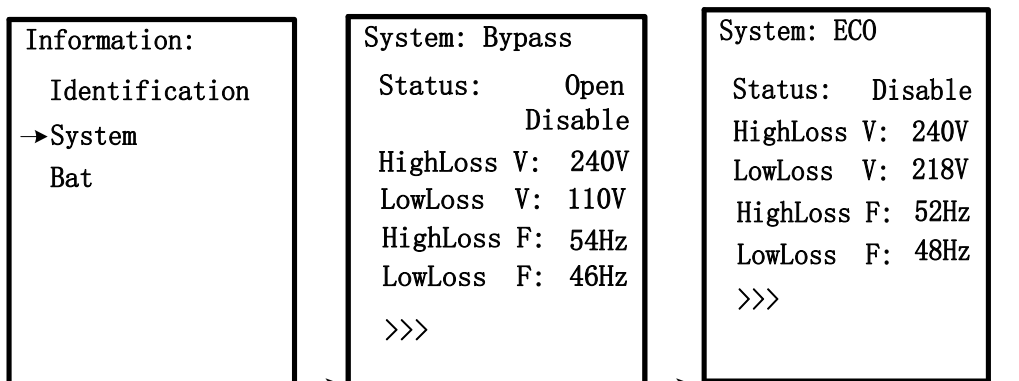

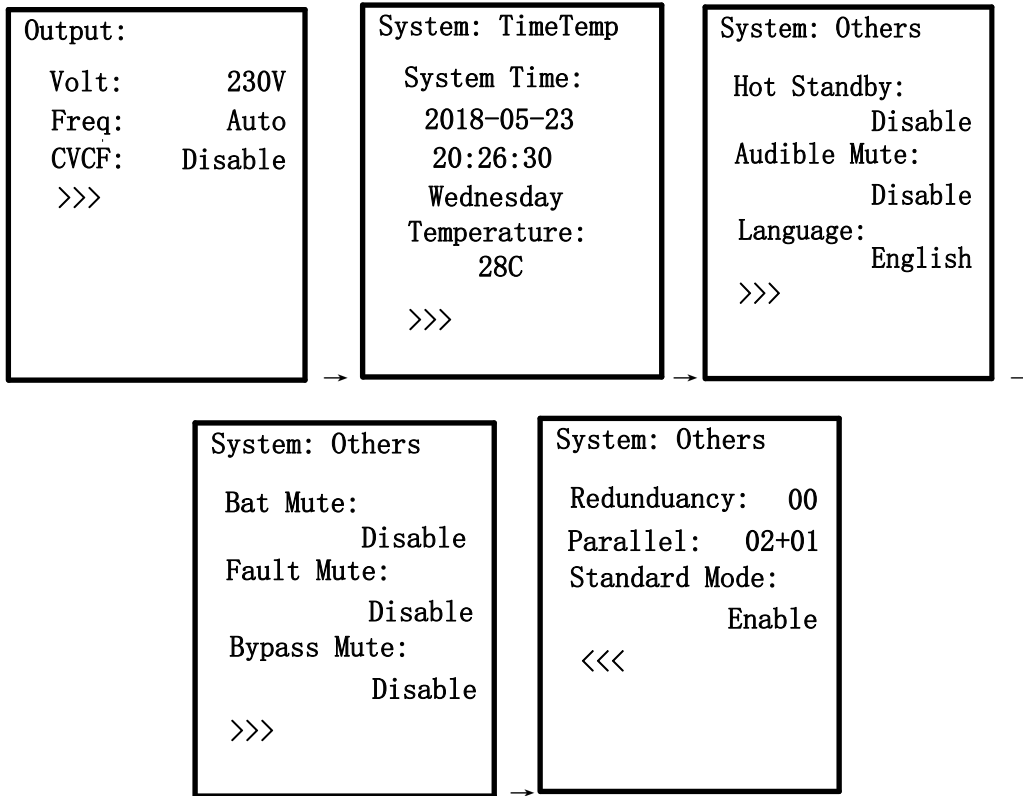

3) Battery shows the battery configuration.

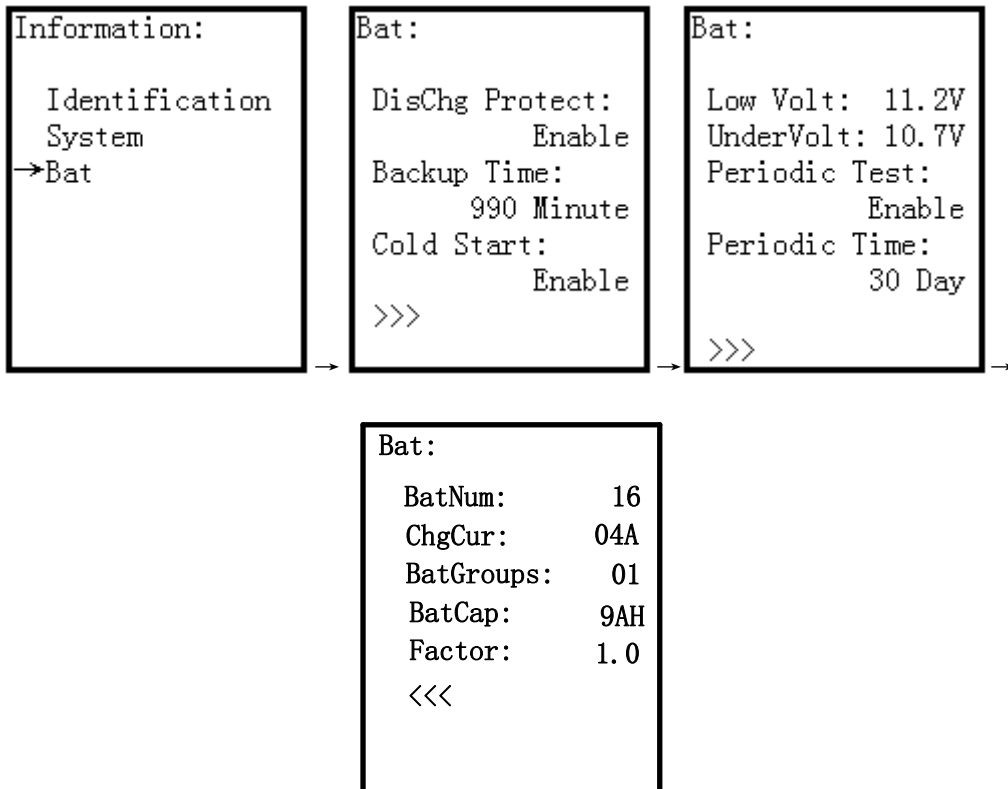

### 3-4-3-6. Events

In Event pages, you can check the current events, history events and reset events.

#### 1) Currents Events

When an event occurs, it will display alarm code in Current Events page. If events exceed more than one page, press "▲" or "▼" button to read other events.

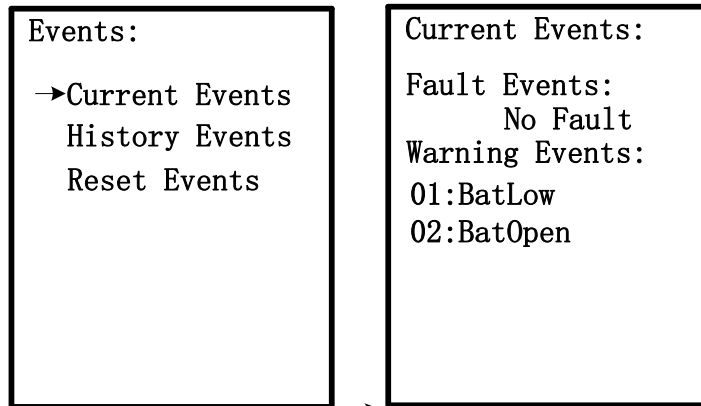

#### 2) History Events

The detailed event information is saved in history events. It can save up to 160 pages in history events. When a warning occurs, it will display alarm code, alarm time and UPS mode. When a fault event occurs, it will display fault code, alarm time/date and UPS operation mode. (Refer to **Chapter 4** Troubleshooting)

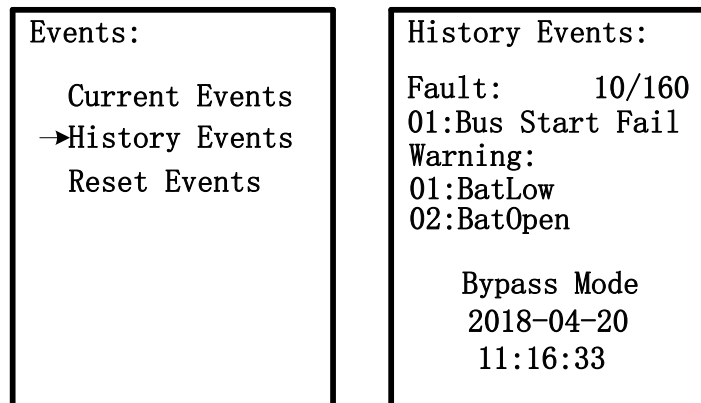

#### 3) Reset Events

It's necessary to enter Maintainer password to enter Reset Events page as shown below. Then, press "▲" or "▼" button to choose "Yes" to clear all history events or "No" to cancel the reset action. The default maintainer password is 0729.



### **3-5. Parallel UPS Operation**

You can add one new UPS into the parallel system when whole system is running at any mode. The additional UPS will automatically match with the Master UPS. Then, fasten the UPS through the screw of mounting ears.

**NOTE:**

- Before parallel operation, please make sure all the connections are correctly (refer to Section 2-5).
- The maximum parallel quantity is 10.
- Be sure the load is less than the maximum capacity of whole UPS system. Otherwise, the UPS will overload fault.



## 4. Trouble Shooting

### 4-1. Warning status

When Fault LED flashes and the buzzer beeps once every second, it means that there are some problems with UPS. Users can see the warning code from LCD panel and refer to the trouble shooting table to check what problem probably happen.

### 4-2. Fault mode

- 1) When Fault LED illuminates and the buzzer beeps continuously, it means that there is a fatal error about UPS. Users can get the fault code from LCD panel. Please refer to the trouble shooting table to check what problems probably happen.
- 2) Don't try to turn on the UPS again before the problem is clear. If the problems can't be fixed, please contact the distributor or service people immediately.
- 3) For emergency case, please cut off the connection from utility, external battery, and output immediately to avoid more risk or danger.

### 4-3. Trouble shooting table

Most of the fault and warnings need to be released by authorized service personnel. Few of them can be solved by users themselves.

LCD Message	Explanation	Solution
Fault 01:Bus Start Fail	The rectifiers could not start within specified time due to low DC-bus voltage.	Turn off UPS and then restart the UPS. If it fails again, contact service personnel.
Fault 02:Bus Over Volt	DC-bus voltage exceeds the maximum voltage.	Contact service personnel.
Fault 03:Bus Under Volt	DC-bus voltage is lower than the minimum value.	Contact service personnel.
Fault 04:Bus Unbalance	DC-bus voltage is not balanced	Contact service personnel.
Fault 05:Bus Volt Vary	DC-bus voltage changes too fast.	Contact service personnel.
Fault 06:PFC Over Curr	PFC current is higher than the maximum current.	Contact service personnel.
Fault 07:Over Temperature	The temperature in UPS is higher than 85°C. At this time, the UPS is off.	Check if the ambient temperature is over specification. Or contact service personnel.
Fault 08:Batt SCR Short	Battery SCR is short circuited.	Contact service personnel.
Fault 11:Inv Start Fail	Inverter voltage cannot reach desired voltage within specified time.	Turn off UPS and then restart it. If it fails again, contact service personnel.
Fault 12:Inv Volt High	Inverter voltage is too high.	Contact service personnel.
Fault 13:Inv Volt Low	Inverter voltage is too low.	Contact service personnel.
Fault 14:Inv Short R	R phase inverter output is short circuited	Contact service personnel.
Fault 15:Inv Short S	S phase inverter output is short circuited	Contact service personnel.
Fault 16:Inv Short T	T phase inverter output is short circuited	Contact service personnel.
Fault 17:Inv Short RS	R-S inverter output is short circuited	Contact service personnel.

Fault 18:Inv Short ST	S-T inverter output is short circuited	Contact service personnel.
Fault 19:Inv Short TR	T-R inverter output is short circuited	Contact service personnel.
Fault 1A:Nega Power R	R phase inverter output negative power is beyond the range.	Contact service personnel.
Fault 1B:Nega Power S	S phase inverter Output Negative Power is beyond the range.	Contact service personnel.
Fault 1C:Nega Power T	T phase inverter Output Negative Power is beyond the range.	Contact service personnel.
Fault 21:Inv STS Open	Inverter relay or STS is open.	Contact service personnel.
Fault 22:Inv STS Short	Inverter relay or STS is short circuited.	Contact service personnel.
Fault 23:Op STS Open	Output relay or STS is open.	Contact service personnel.
Fault 24:Op STS Short	Output relay or STS is short circuited.	Contact service personnel.
Fault 25:Wiring Fail	The wiring is wrong.	Contact service personnel.
Fault 26:Bat Fuse Open	Battery fuse is broken.	Contact service personnel.
Fault 27:Charge Short	The battery is short circuited.	Contact service personnel.
Fault 31:Para Comm Fail	The communication between UPS modules is interrupted.	Contact service personnel.
Fault 32:Host Line Fail	The host line between UPS modules fails.	Contact service personnel.
Fault 33:OP Curr Unbal	The load share line between UPS modules fails.	Contact service personnel.
Fault 34:Ver Incompat	The firmware version between UPS modules is incompatible.	Contact service personnel.
Fault 41:DSP Comm Fail	The internal communication in UPS module is interrupted.	Contact service personnel.
Fault 42:Over load	Heavy overload causes UPS fault.	Reduce some load.
Fault 43:Charger Fail	Battery polarity is connected reversely or charger voltage is abnormal.	Contact service personnel.
Fault 44:Model Fault	UPS model is not able to identify.	Contact service personnel.
Fault 45:Mcu Comm Fail	As stated.	Contact service personnel.
Fault 46:CT Satiation	Load current sensor is abnormal.	Contact service personnel.
Fault 47:Fan Fault	The two fans are stuck or broken.	Make sure fans work well when UPS is working.
Warning 01:BatLow	Battery voltage is low.	Charge the battery when the mains is normal.
Warning 02:BatOpen	Battery is not connected.	<ol style="list-style-type: none"> <li>1. Check battery breaker status.</li> <li>2. Check if the battery connection is well connected.</li> <li>3. Check the setting of Nominal Battery voltage.</li> <li>4. Contact service personnel if necessary</li> </ol>
Warning 03:BatPhaseLoss	The voltage between positive and negative battery is different.	Check the battery connection.
Warning 04:LineIpNLoss	Neutral loss	Check if the Neutral connection is well and contact service personnel.
Warning 05:LinePhaseError	As stated.	Check if the Mains phase sequence is correct and contact service personnel.

Warning 06:LineVoltError	As stated.	Check if the input wiring is correct or contact service personnel
Warning 07:LinePhaseFail	As stated.	Contact service personnel
Warning 08:OverCharge	Battery voltage is too high.	Check the setting of Nominal Battery voltage and contact service personnel.
Warning 09:ChgFail	Battery voltage is detected as low level. However, the charge is able to work.	Contact service personnel.
Warning 0A:OverTemp	The temperature in UPS is higher than 75°C. At this time, the UPS is still running.	Check if the ambient temperature is over specification. Or contact service personnel.
Warning 0B:PFCCurUnbal	PFC current is unbalance.	Contact service personnel
Warning 0C:FanError	Fan error.	Check if the fan is blocked or contact service personnel.
Warning 0D:LineFuseOpen	Fuse is broken.	Turn off UPS and replace a good one with the broken one. If UPS fails again after you do this, contact the service personnel.
Warning 0E:IICEepromFail	EEPROM operation error	Contact service personnel.
Warning 11:BypassIpNLoss	Neutral loss.	Check if the Neutral connection is well and contact service personnel.
Warning 12:BpsPhaseError	Bypass phase error.	Check if the Bypass phase sequence is correct and contact service personnel.
Warning 13:BpsVoltError	Bypass voltage error.	Check the wiring or contact service personnel
Warning 14:BpsPhaseFail	As stated.	Contact service personnel
Warning 15:OverLoad	In line mode, the connected devices are demanding more power than the UPS can supply.	Reduce some load and check output Load-Capacity in specification.
Warning 16:OverLoadLock	The connected devices are demanding more power than the UPS can supply. UPS will transfer to bypass mode from line mode.	Reduce some load and check output Load-Capacity in specification.
Warning 17:EpoActive	Check the EPO connector.	Check if the connector is loose when EPO acts abnormally.
Warning 18:MaintainOpen	The UPS is in maintenance mode.	Check if external maintenance bypass signal port is not connected to 2-pin EPO port on the optional controller module when it acts abnormally.
Warning 19:LineDiff	Each module gets different line voltage when they are in parallel.	Contact service personnel.
Warning 1A:BypassDiff	Each module gets different bypass voltage when they are in parallel.	Contact service personnel.
Warning 1B:InvCurUnbal	As stated.	Contact service personnel.
Warning 1C:BpsUnstable	UPS switches between bypass mode and standby mode five times in 30 minutes due to abnormal utility.	Contact service personnel.

Warning 1D:RedundancyFail	As stated.	Check if redundancy setting is correct or not. Then, contact service personnel.
Warning! Battery Age Alert	Battery life is expired.	Check if the battery has been used over its service age. Or contact service personnel.
Warning! Dry Contact Input Alarm 1	As stated.	Remove the node
Warning! Dry Contact Input Alarm 2	As stated.	Remove the node
Warning! Control Module SPS 1 Fault	As stated.	Contact service personnel.
Warning! Control Module SPS 2 Fault	As stated.	Contact service personnel.

## 5. Storage and Maintenance

### 5-1. Storage

Store the UPS covered and upright in a cool, dry location. During storage, recharge the battery in accordance with the following table:

Storage Temperature	Recharge Frequency	Charging Duration
-25°C - 40°C	Every 3 months	1-2 hours
40°C - 45°C	Every 2 months	1-2 hours

**For the battery pack, please charge it at least 7 hours before storage.**

### 5-2. Maintenance



The UPS system operates with hazardous voltages. Repairs may be carried out only by qualified maintenance personnel.



Even after the unit is disconnected from the mains, components inside the UPS system are still connected to the Battery packs which are potentially dangerous.



Before carrying out any kind of service and/or maintenance, disconnect the batteries and verify that no current is present and no hazardous voltage exists in the terminals of high capability capacitor such as BUS-capacitors.



Only persons are adequately familiar with batteries and with the required precautionary measures may replace batteries and supervise operations. Unauthorized persons must be kept well away from the batteries.



Verify that no voltage between the battery terminals and the ground is present before maintenance or repair. In this product, the battery circuit is not isolated from the input voltage. Hazardous voltages may occur between the battery terminals and the ground.



Batteries may cause electric shock and have a high short-circuit current. Please remove all wristwatches, rings and other metal personal objects before maintenance or repair, and only use tools with insulated grips and handles for maintaining or repairing.



When replace the batteries, install the same number and same type of batteries.



Do not attempt to dispose of batteries by burning them. This could cause battery explosion. The batteries must be rightly disposed according to local regulation.



Do not open or destroy batteries. Escaping electrolyte can cause injury to the skin and eyes. It may be toxic.



Please replace the fuse only with the same type and amperage in order to avoid fire hazards.



Do not disassemble the UPS system.

## 6. Specifications

MODEL	3/3-10K	3/1-10K	1/1-10K	2/2-6K LV	3/3-10K LV
PHASE	3 phase in / 3 phase out	3 phase in / 1 phase out	1 phase in / 1 phase out	2 phase in / 2 phase out	3 phase in / 3 phase out
CAPACITY	10000 VA/ 10000 W			6000 VA/ 6000 W	10000 VA/ 8000 W
CABINET CAPACITY	100KVA/100KW			60KVA/60KW	100KVA/80KW
ONE POWER MODEL CAPACITY	10KVA/10KW			6KVA/6KW	10KVA/8KW
MAX. POWER MOUDULE NO.	10				
MAX. BATTERY SET NO.	10				
<b>INPUT</b>					
Nominal Voltage	3 x 360VAC/380VAC/400VAC/415 VAC (3Ph+N+PE)	208VAC/220 VAC/230VAC/ 240VAC (1Ph+N+PE)	100/200, 110/220, 120/208, 120/240, 127/220 VAC (2P+N+PE)	3 x 173VAC/191VAC /200VAC/ 208VAC/220VAC (3Ph+N+PE)	
Voltage Range	190-520 VAC (3-phase) @ 50% load 305-478 VAC (3-phase) @ 100% load	110-300 VAC @ 50% load 176-276 VAC @ 100% load	88-155VAC (L-N) 152-269VAC (L-L)	88V-155V (L-N)	
Frequency Range	40~70Hz				
Power Factor	$\cong 0.99$ @ 100% load				
THDi	< 5% @ full linear load				
<b>OUTPUT</b>					
Output Voltage	360VAC/380V AC/400VAC/41 5VAC (3Ph+N)	208*/220/230/240VAC (L+N)	100/200, 110/220, 120/208, 120/240, 127/220 VAC (2P+N)	173VAC/191VAC /200VAC/ 208VAC/220VAC (3Ph+N)	
AC Voltage Regulation (Batt. Mode)	$\pm 1\%$				
Frequency Range (Synchronized Range)	46~54Hz or 56~64Hz				
Frequency Range (Batt. Mode)	50 Hz $\pm$ 0.1 Hz or 60 Hz $\pm$ 0.1 Hz				
Current Crest Ratio	3:1 (max.)				
Harmonic Distortion	$\leq 2\%$ THD (Linear Load); $\leq 4\%$ THD (Non-linear Load)			$\cong 3\%$ (Linear Load); $\cong 5\%$ (Non-linear Load)	
Transfer Time	AC Mode to Batt. Mode	zero			
	Inverter to Bypass	zero			
Waveform (Batt. Mode)	Pure Sinewave				
<b>EFFICIENCY</b>					
AC Mode	94%	94%	93.5%	91%	91%
ECO Mode	97%				
Battery Mode	93.5%	93%	92.5%	91.5%	90%
<b>BATTERY/CHARGER</b>					
Battery Voltage	$\pm 12V$				
Battery Numbers	16 ~ 20 pcs (adjustable) x 2			8 pcs x 2	
Nominal Voltage	+/-192V (12V x 32 pcs)			+/-96V (12V x 16 pcs)	

Maximum Voltage	+/- 240V (12V x 40 pcs)	+/-96V (12V x 16 pcs)
Minimum Voltage	+/-192V (12V x 32 pcs)	+/-96V (12V x 16 pcs)
Charging Voltage	± 218V	± 109V
Typical Recharging Time	9 hours recover to 90% capacity	
Charging Current	+/- 4A	
<b>INDICATORS</b>		
LCD/LED Display	UPS status, Load level, Battery level, Input/Output voltage, Discharge timer, and Fault conditions	
<b>PHYSICAL</b>		
Dimension, D X W X H (mm)	678 X 418 X 129	
Net Weight (kgs)	20.5	20.5
	20.5	17.6
		20.5
<b>ENVIRONMENT</b>		
Operation Humidity	0-95 % RH @ 0- 40°C (non-condensing)	
Noise Level	Less than 55dB @ 1 Meter	Less than 58dB @ 1 Meter
<b>MANAGEMENT</b>		
Smart USB	Supports Windows® 2000/2003/XP/Vista/2008, Windows® 7/8, Linux and MAC	
Optional SNMP	Power management from SNMP manager and web browser	

\*Derate capacity to 90% of capacity when the output voltage is adjusted to 208VAC.

\*\*Product specifications are subject to change without further notice.